

WHISTLE



2025



CONTENT

ROAD *04*

GRAVEL *16*

E-BIKE FULL SUSPENDED *22*

E-BIKE HARDTAIL *54*

E- GRAVEL *65*

E- URBAN *74*

MTB FULL SUSPENDED *98*

MTB HARDTAIL *102*

ATALA E WHISTLE, DUE MARCHI ED UNA MISSION: "ONE RIDE AT A TIME"

Progettiamo e produciamo in Italia tutte le nostre eBike e le nostre biciclette in fibra di carbonio. Vengono prodotte in stabilimenti dedicati con macchinari specifici e personale specializzato. Le nostre biciclette sono conformi alle normative europee di sicurezza e vengono testate sia in laboratorio che sul campo, in particolare dal nostro team professionistico eMTB.

Sviluppa tutti i suoi telai ed i suoi sistemi elettrici con i più importanti fornitori mondiali. Il team Whistle si è dedicato a studi approfonditi del mondo Bike e eBike, analizzando nel minimo dettaglio l'integrazione tra i kit elettrici, la componentistica all'avanguardia ed il design con un solo obiettivo: soddisfare le esigenze di tutti gli utenti.

Per la stagione 2025, propone una gamma sempre più completa; dando particolare rilievo ad un materiale molto leggero e al contempo di grande resistenza, in grado di fornire rigidezza e flessibilità nei punti critici.. il carbonio!

Essere competitivi ed osare sono quindi le parole chiave per Whistle: proporre innovazioni, rompere gli schemi pur nel rispetto della forte tradizione che la contraddistingue.

ATALA E WHISTLE SONO LE BICICLETTE ELETTRICHE PIÙ DISTRIBUITE IN ITALIA

Un grande successo nelle vendite, presso i punti di vendita specializzati, negli ultimi anni ed anche nel 2023, testimoniato dalle ricerche di settore (fonte ricerca di mercato MODUS – ANCMA).

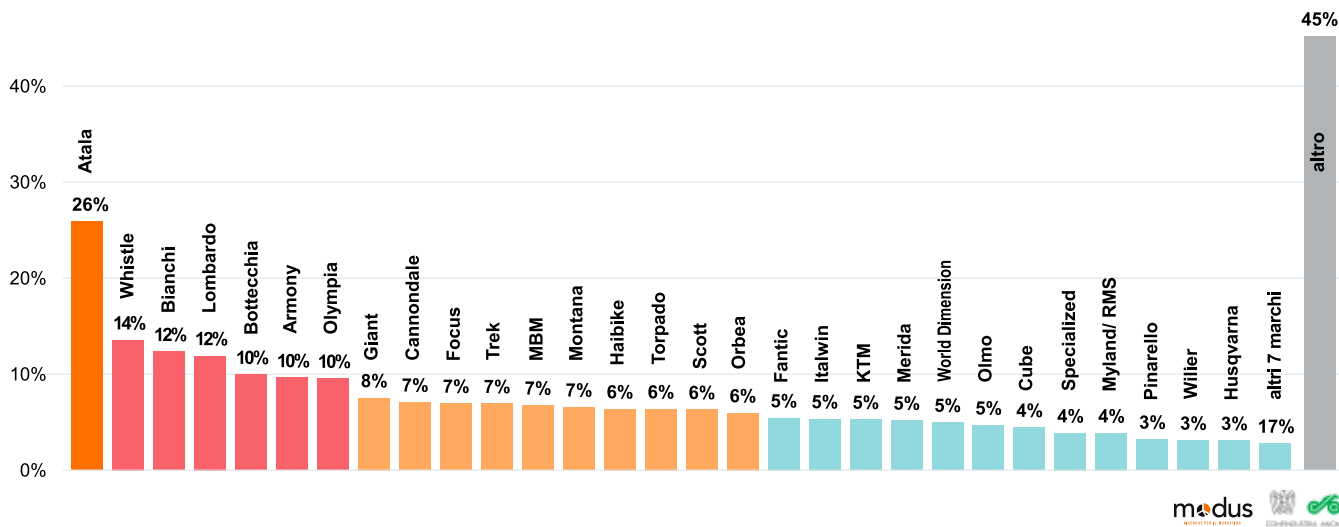

ATALA AND WHISTLE, TWO BRANDS AND ONE MISSION: "ONE RIDE AT A TIME"

We design and produce all our eBikes and carbon fiber bicycles in Italy. They are produced in dedicated factories with specific machinery and specialized personnel. Our bicycles comply with European safety regulations and are tested both in the laboratory and in the field, in particular by our professional eMTB team. It develops all its frames and electrical systems with the most important global suppliers. The Whistle team has dedicated itself to in-depth studies of the Bike and eBike world, analyzing in great detail the integration between electrical kits, cutting-edge components and design with a single goal: to satisfy the needs of all users.

For the 2025 season, it offers an increasingly complete range; giving particular emphasis to a very light and at the same time highly resistant material, capable of providing rigidity and flexibility in critical points... carbon!

Being competitive and daring are therefore the key words for Whistle: proposing innovations, breaking the mold while respecting the strong tradition that distinguishes it.

ATALA AND WHISTLE ARE THE MOST DISTRIBUTED ELECTRIC BICYCLES IN ITALY

A great success in sales, at specialized stores, in recent years and also in 2023, as demonstrated by sector research (source: MODUS market research – ANCMA).

**LE NOSTRE BICI
SONO SOTTOPOSTE
A TEST IN LABORATORIO E
SUL CAMPO DAI NOSTRI ATLETI
PER GARANTIRE STANDARD
QUALITATIVI E PERFORMANCE**

***OUR BIKES ARE SUBJECTED
TO LABORATORY TESTS AND
ON THE FIELD BY OUR ATHLETES
TO ENSURE QUALITY AND
PERFORMANCE STANDARDS***



ROAD

Il telaio e la forcella Vaero sono certificati UCI e realizzati utilizzando carbonio Toray T700 e T800. Il risultato è un telaio monoscocca, aerodinamico, rigido, leggero e preciso, con grande capacità d'assorbimento delle vibrazioni. Le geometrie da competizione la rendono adatta a tutti i tipi di percorso.

La filosofia che contraddistingue i modelli Vaero è la realizzazione di un prodotto da competizione, dai dettagli raffinati e dall'incredibile rapporto qualità-prezzo.

La Vaero Dura Ace in taglia 54 pesa 7,4 kg

The Vaero frame and fork are UCI certified and made using Toray T700 and T800 carbon. The result is a monocoque frame, aerodynamic, rigid, light and precise, with great vibration absorption capacity.

The racing geometry makes it suitable for all types of routes.

The philosophy that distinguishes the Vaero models is the creation of a racing product, with refined details and an incredible quality-price ratio.

The Vaero Dura Ace in size 54 weighs 7.4 kg





L'azienda produttrice si riserva il diritto di cambiare immagini, colori, specifiche e prezzi senza preavviso.
The manufacturing company takes the right to change pictures, colors, specs and prices without prior notice.

ROAD

VAERO

Il telaio monoscocca in carbonio permette di avere come vantaggi:

Leggerezza

La Vaero Dura Ace in taglia 54 pesa 7,4 kg.

Rigidità

L'assenza di giunzioni offre una migliore distribuzione delle forze, aumentando la rigidità e la reattività della bici.

Comfort

Assorbimento delle vibrazioni.

Aerodinamica

La struttura del monoscocca consente forme più fluide e ottimizzate per ridurre la resistenza con l'aria.

The monocoque carbon frame allows you to have the following advantages:

Lightness

The Vaero Dura Ace in size 54 weighs 7.4 kg.

Rigidity

The absence of joints offers a better distribution of forces, increasing the rigidity and reactivity of the bike.

Comfort

Vibration absorption.

Aerodynamics

The monocoque structure allows for more fluid and optimized shapes to reduce air resistance.



L'adesivo UCI significa che l'Unione Ciclistica Internazionale ha verificato e approvato che la bicicletta rispetta i requisiti tecnici della normativa. Il processo di approvazione è fatto per ogni taglia.

The UCI sticker means that the Int. Cycling Union has verified and approved that the bicycle meets all the technical requirements of the regulation. The approval process is done for each size.



Nuove SC45, cerchio più largo e più veloce. Sviluppate in galleria del vento, dimostrano una resistenza all'avanzamento inferiore rispetto al modello precedente. Questo permette d'installare una copertura maggiorata senza sacrificare l'aerodinamica.

New SC45, wider and faster rim. Developed in the wind tunnel, they demonstrate lower resistance to advancement than the previous model. This allows for the installation of a large coverage without sacrificing aerodynamics.personal bests.



Dischi da 140 sul posteriore e 160 sull'anteriore. Perno passante per conferire al telaio una più rigidità ed una maggiore reattività nella guida.

140 discs on the rear and 160 on the front. Thru axle to give the frame more rigidity and greater responsiveness in driving.



Coperture Continental GP5000 Tubeless ready con sezione 28mm.

Continental GP5000 Tubeless ready tires with 28mm section.



Metron 5D e 5D EVO è il più rigido e aerodinamico manubrio integrato. La piega e l'attacco integrato del marchio FSA sono predisposti per il passaggio interno dei cavi del cambio elettronico.

Metron 5D and 5D EVO is the stiffest and most aerodynamic integrated handlebar. The FSA brand integrated handlebar and stem are prepared for internal routing of electronic shift cables.



Sella Fizik Anteres Vento R1 con rail in carbonio.

Fizik Antares Vento R1 saddle with carbon rail.

ROAD

VAERO DURA ACE



FRAME	Full Carbon T700 e T800 Integrate Cable Routing BB-PressFit 72x41 Ready for 700x30
FORK	Full Carbon 12x100 mm thru axle Ready for 700x30
HEADSET	FSA No.55R 1,5"
CRANKSET	Shimano Dura Ace Power Meter FC-R9200 12s 52/36
REAR DERAILLEUR	Shimano Dura Ace Di2 RDR9250
FRONT DERAILLEUR	Shimano Dura Ace Di2 FDR9250F
SHIFTERS LEVERS	Shimano Dura Ace Di2 ST-R9270
BRAKES	Shimano Dura Ace BR-R9200, Rotor (160 mm /140 mm)
CASSETTE	Shimano CS-R9200 12s 11/30
CHAIN	Shimano 12s CNM9100
WHEELS	VISION SC45 Full Carbon Tubeless ready
HANDLEBAR	FSA Metron 5D EVO One-Piece Full Carbon Cockpit Integrate Cable Routing
SEATPOST	Full Carbon 0mm Offset 400 mm lenght
SADDLE	Prologo Nago R4 (carbon rail) / Fizik Antares Vento R1 (carbon rail)
TYRES	Continental GP5000S TR (Tubeless Ready) 700x28

BLACK/CROME

49	0116882100
52	0116882110
54	0116882120
56	0116882130
58	0116882140

SHIMANO DURA ACE POWER METER FC-R9200



ROAD

VAERO ULTEGRA



FRAME	Full Carbon T700 e T800 Integrate Cable Routing BB-PressFit 72x41 Ready for 700x30
FORK	Full Carbon 12x100 mm thru axle Ready for 700x30
HEADSET	FSA No.55R 1,5"
CRANKSET	Shimano Ultegra FC-R8100 12s 52/36
REAR DERAILLEUR	Shimano Ultegra Di2 RD-R8150F
FRONT DERAILLEUR	Shimano Ultegra Di2 FD-R8150F
SHIFTERS LEVERS	Shimano Ultegra Di2 ST-R8150
BRAKES	Shimano Ultegra BR-R8100, Rotor (160 mm / 140 mm)
CASSETTE	Shimano CS-R8100 12s 11/30
CHAIN	Shimano 12s CNM8100
WHEELS	VISION SC45 Full Carbon Tubeless ready
HANDLEBAR	FSA Metron 5D EVO One-Piece Full Carbon Cockpit Integrate Cable Routing
SEATPOST	Full Carbon 0mm Offset 400 mm lenght
SADDLE	Prologo Nago R4 (carbon rail) / Fizik Antares Vento R1 (carbon rail)
TYRES	Continental GP5000S TR (Tubeless Ready) 700x28

BLACK/CROME	
49	0116882000
52	0116882010
54	0116882020
56	0116882030
58	0116882040

ROAD

VAERO 105



FRAME	Full Carbon T700 e T800 Integrate Cable Routing BB-PressFit 72x41 Ready for 700x30
FORK	Full Carbon 12x100 mm thru axle Ready for 700x30
HEADSET	FSA No.55R 1,5"
CRANKSET	Shimano 105 FCR7100 12s 50/34
REAR DERAILLEUR	Shimano 105 mechanical RD-R7100
FRONT DERAILLEUR	Shimano 105 mechanical FD-R7100F
SHIFTERS LEVERS	Shimano 105 mechanical ST-R7120
BRAKES	Shimano 105 BR-BR-7100, Rotor (160 mm / 140 mm)
CASSETTE	Shimano CS-R7101 12s 11/34
CHAIN	Shimano 12s CNM7100
WHEELS	Whistle C35 Full Carbon Tubeless ready
HANDLEBAR	Whistle Vaero One-Piece Full Carbon Cockpit Integrate Cable Routing
SEATPOST	Full Carbon 0mm Offset 400 mm lenght
SADDLE	Selle Royal SRX // Whistle performance
TYRES	Continental Ultra Sport 700x28

BLACK/WHITE	
49	0116882200
52	0116882210
54	0116882220
56	0116882230
58	0116882240

NUOVE RUOTE WHISTLE C35

Cerchi in fibra di carbonio con profilo aerodinamico e canale da 23 mm, adatto a coperture fino a 32 mm.

Mozzi made in Italy by Radiale, J100 e J142 montati con cuscinetti sigillati a basso coefficiente d'attrito e corpetti con tecnologia Ratchet a 36 punti d'ingaggio.

Le ruote sono montate a 28 raggi.

I nuovi mozzi Radiale J110 e J142 sono montati con cuscinetti sigillato con basso coefficiente d'attrito e con corpetti con tecnologia Ratchet. Le ruote sono montate a 28 raggi.

Disponibili in After Market.

Carbon fiber rims with aerodynamic profile and 23 mm channel, suitable for tires up to 32 mm.

Hubs made in Italy by Radiale, J100 and J142 mounted with sealed bearings with low friction coefficient and bodies with Ratchet technology with 36 points of engagement.

The wheels are mounted with 28 spokes.

Available in After Market.



NUOVO COCKPIT IN CARBONIO

Sistema di attacco e piega integrato, in fibra di carbonio, con passaggio cavi integrati.

Il manubrio è stato progettato con i nostri atleti per poter proporre la miglior geometria garantendo un ottimo comfort durante la guida.

Studiato e testato per poter garantire una buona rigidità con qualità di resistenza alle sollecitazioni ed i carichi.

L'aerodinamica è una qualità del nuovo manubrio integrato, che si sposa perfettamente con il telaio Vaero.

Integrated stem and bend system, in carbon fiber, with integrated cable routing.

The handlebar was designed with our athletes to be able to propose the best geometry guaranteeing excellent comfort while riding.

Designed and tested to be able to guarantee good rigidity with resistance qualities to stress and loads.

Aerodynamics is a quality of the new integrated handlebar, which marries perfectly with the Vaero frame.



MODOC FLAT BAR HD SORA



FRAME	Alu. Formed triple butted, Flat Mount disc brake, internal cables
FORK	Road Alu, Flat Mount disc brake
HEADSET	FSA No.16CC 1 1/8
CRANKSET	Byte Alu Compact 34/50, BSA
REAR DERAILLEUR	Shimano Sora RD-R3000 9s
SHIFTERS LEVERS	Shimano Sora FD-R3000
BRAKES	Shimano Sora ST-R3000 Flat handlebar 9x2s
CASSETTE	Tektro Hydraulic disc HD-R290 Flat mount, 3 fingers
CHAIN	Shimano CS-HG200 9s, 11/34T
PEDALS	Alu Sport
WHEELS	Whistle Road Disc INT, QR
STEM	Byte Alu Oversize
HANDLEBAR	Byte Alu Oversize flat
SEATPOST	Byte Alu 27,2
SADDLE	Selle Royal/Whistle Active with hole
TYRES	Schwalbe G-One Allround Performance700x35 Gravel

BLACK/ORANGE	
M	0116835800
L	0116835810

MODOC FLAT BAR CLARIS



FRAME	Alu. Formed triple butted, internal cable
FORK	Road Alu
HEADSET	FSA No.16CC 1 1/8
CRANKSET	Byte Alu Compact 34/50, BSA
REAR DERAILLEUR	Shimano Claris RD-R2000 8s
SHIFTERS LEVERS	Shimano Claris FD-R2000
BRAKES	Shimano Claris ST-R2000 Flat handlebar 8x2s
CASSETTE	Alu caliper
CHAIN	Shimano CS-HG41 8s, 11/34T
PEDALS	Alu Sport
WHEELS	Whistle Racing
STEM	Byte Alu Oversize
HANDLEBAR	Byte Alu Oversize flat
SEATPOST	Byte Alu 27,2
SADDLE	Selle Royal/Whistle Active with hole
TYRES	Schwalbe Lugano 700x28, puncture protection

GREY/NEON RED	
M	0116835700

GRAVEL

KIOWA

Telaio in carbonio monoscocca Toray T700 disegnata con geometrie Gravel, alla possibilità di montare gomme fino a 47mm. E' un telaio leggero e resistente e con grande capacità ad assorbire vibrazioni.

Il telaio monoscocca in carbonio permette di avere come vantaggi:

Leggerezza

La fibra di carbonio è il materiale che offre il miglior rapporto peso/resistenza.

Rigidità

L'assenza di giunzioni offre una migliore distribuzione delle forze, aumentando la rigidità e la reattività della bici.

Comfort

Assorbimento delle vibrazioni.

Aerodinamica

La struttura del monoscocca consente forme più fluide e ottimizzate per ridurre la resistenza con l'aria.

Toray T700 monocoque carbon frame designed with Gravel geometry, with the possibility of mounting tires up to 47mm.

It is a light and resistant frame with great capacity to absorb vibrations.

The monocoque carbon frame allows you to have the following advantages:

Lightness

Carbon fiber is the material that offers the best weight/strength ratio.

Rigidity

The absence of joints offers a better distribution of forces, increasing the rigidity and reactivity of the bike.

Comfort

Vibration absorption.

Aerodynamics

The monocoque structure allows for more fluid and optimized shapes to reduce air resistance.





GRAVEL

KIOWA GRX822



FRAME	Full Carbon T700 Integrate Cable Routing BSA Ready for 700x47C
FORK	Full Carbon 12x100 mm thru axle Ready for 700x47C
HEADSET	FSA No.55R 1,5"
CRANKSET	Shimano GRX FC-RX8201 12s 40
REAR DERAILLEUR	Shimano GRX RD-RX822SGS 12s
SHIFTERS LEVERS	Shimano GRX ST-RX820
BRAKES	Shimano GRX BR-RX820, Rotor 160 mm
CASSETTE	Shimano CS-M8100 12s 10/51
CHAIN	Shimano 12s CNM7100
WHEELS	Whistle C35 Full Carbon Tubeless ready
STEM	FSA ST-OS-188/SMR, Alu 3D forged, int cables
HANDLEBAR	FSA Adventure AGX Compact, Alu 3D forged, int cables
SEATPOST	Full Carbon 0mm Offset 400 mm lenght
SADDLE	Selle Royal SRX // Whistle performance
TYRES	Schwalbe G-One Allround 700x40

CARBON/SAND	
48	0116882300
51	0116882310
54	0116882320
57	0116882330
60	0116882340

RUOTE IN CARBONIO WHISTLE C35

Tubeless ready, predisposte per coperture con sezione fino a 47mm



GRAVEL

KIOWA GRX400



FRAME	Full Carbon T700 Integrate Cable Routing BSA Ready for 700x47C
FORK	Full Carbon 12x100 mm thru axle Ready for 700x47C
HEADSET	FSA No.55R 1,5"
CRANKSET	Shimano GRX FC-RX600, 2 pieces, 46/30, Tiagra BB-RS500 BSA Fsa AGX+ Gossamer PRO 46/30, FSA MegaExo BB-620 BSA
FRONT DERAILLEUR	Shimano GRX FD-RX400F
REAR DERAILLEUR	Shimano GRX RD-RX400 10s
SHIFTERS LEVERS	Shimano GRX ST-RX400 10x2s
BRAKES	Shimano GRX BR-RX400 hydraulic disc, Rotor 160mm CL
CASSETTE	Shimano Tiagra CS-HG500 10s 11/34
WHEELS	Shimano WH-RS171, 28 spokes, 12mm e-thru, CL / Mavic
STEM	FSA ST-OS-188/SMR, Alu 3D forged, int cables
HANDLEBAR	FSA A-Wing HB-RD-311S AGX Alu
SEATPOST	Full carbon 0mm Offset 400 mm length
SADDLE	Selle Italia Model X Super Flow
TYRES	Schwalbe G-One Allround 700x35

CARBON/SAND	
48	0116859100
51	0116859110
54	0116859120
54 (MAV)	0116859145
57	0116859130
60	0116859140

GRAVEL

KIOWA A GRX400



FRAME	Full Alu Internal Cable Routing Pressfit Ready for 700x47C
FORK	Full Carbon 12x100 mm thru axle Ready for 700x47C
HEADSET	FSA No.55R 1,5"
CRANKSET	Shimano GRX FC-RX60010s 46/30
REAR DERAILLEUR	Shimano GRX RD-RX400 10s
FRONT DERAILLEUR	Shimano GRX RD-RX400F
SHIFTERS LEVERS	Shimano GRX ST-RX400
BRAKES	Shimano GRX BR-RX400, Rotor 160 mm
CASSETTE	Shimano CS-HG500 10s 11/34
CHAIN	Shimano 10s CNHG54
FRONT HUB	Radiale J100x12, 32h
REAR HUB	Radiale J142x12, 32h, MS
RIMS	Radiale G55, eDesign Asymmetric, Tubeless Ready, 622x24
STEM	Alu, Barbore 31,8mm, +-6°
HANDLEBAR	Alu, Gravel design, Drop 125mm
SEATPOST	Alu 27,2mm
SADDLE	Selle Royal SRX // Whistle performance
TYRES	Schwalbe G-One Comp 700x45

BLACK/BLUE	
48	0116882500
52	0116882510
55	0116882520
58	0116882530



E-MTB FULL SUSPENDED

Geometrie da competizione con corsa alla forcella fino a 170mm e alla triangolo posteriore 160mm.
Angolo di sterzo e sella per grande stabilità e precisione in curva.
Leggere e resistenti grazie ai nuovi materiali.

Il telaio monoscocca in carbonio permette di avere come vantaggi:

Leggerezza

La fibra di carbonio è il materiale che offre il miglior rapporto peso/resistenza.

Rigidità

L'assenza di giunzioni offre una migliore distribuzione delle forze, aumentando la rigidità e la reattività della bici.

Comfort

Assorbimento delle vibrazioni.

Aerodinamica

La struttura del monoscocca consente forme più fluide e ottimizzate per ridurre la resistenza con l'aria.

Racing geometry with fork travel up to 170mm and rear triangle 160mm.

Head and seat angle for great stability and precision in curves.

Light and resistant thanks to the new materials.

The monocoque carbon frame allows you to have the following advantages:

Lightness

Carbon fiber is the material that offers the best weight/strength ratio.

Rigidity

The absence of joints offers a better distribution of forces, increasing the rigidity and reactivity of the bike.

Comfort

Vibration absorption.

Aerodynamics

The monocoque structure allows for more fluid and optimized shapes to reduce air resistance.





B-RUSH CARBON

Due nuovi telai in carbonio pronti ad accogliere il nuovo motore Bosch CX (BDU384) e la batteria da 800 o 600Wh senza di bisogno di adattatore.

Il primo telaio realizzato con mix di carbonio Toray T700 e T800, contraddistinto dalle viti oro, raggiungere una riduzione di peso pari a 1300gr, rispetto al solo telaio e carro 2024.

Con il secondo realizzato con fibra in carbonio Toray T700, contraddistinto dalle viti nere, si ottiene una riduzione di 1000gr, rispetto al solo telaio e carro 2024.

Questi traguardi sono stati raggiunti mantenendo stabilità, rigidità e resistenza tipiche della gamma B-Rush. Completamente ridisegnata in tutti i suoi dettagli.

Two new carbon frames ready to accommodate the new Bosch CX engine (BDU384) and the 800 or 600 Wh battery without the need for an adapter.

The first frame made with a mix of Toray T700 and T800 carbon, distinguished by the gold screws, achieves a weight reduction of 1300gr, compared to the 2024 frame and swingarm alone.

With the second made with Toray T700 fiber, distinguished by the black screws, a reduction of 1000gr is achieved, compared to the "24 frame and swingarm alone.

These goals have been achieved while maintaining the stability, rigidity and resistance typical of the B-Rush range. Completely redesigned in all its details.





Nuova cover motore, in fibra di carbonio, più leggera e ottimizzata per il raffreddamento necessario per il motore CX (BDU38). Cover predisposta per il BCM Bosch.

New engine cover, in carbon, lighter and optimized for the cooling needed for the CX engine (BDU38). The cover is prepared for the BCM Bosch.



Nuova cover batteria, in fibra di carbonio, alleggerita ma sempre con un alto livello di resistenza a sollecitazioni e urti.

New battery cover, in carbon fiber, lightened but still with a high level of resistance to stress and impacts.



Nuovo design del telaio che integra l'ammortizzatore. Il telaio è predisposto anche per il Power More Bosch.

New frame design that integrates the shock absorber. The frame is also prepared for the Bosch Power More.

Rocker più leggero, snello ma rigido e con ogni movimento su cuscinetti.

Lighter rocker, lean but stiff and wit every movement on bearings.



L'attacco cambio SRAM UHD (Universal Hanger Derailleur) è progettato per riallineare il cambio automaticamente e ridurre il rischio di rottura in caso di urti.

The SRAM UHD (Universal Hanger Derailleur) derailleur hanger is designed to automatically realign the derailleur and reduce the risk of breakage in the event of impacts.



Porta di ricarica riprogettata per facilitare l'apertura e la chiusura e con una miglior resistenza alle infiltrazioni dell'acqua.

Redesigned charging port for easier opening and closing and improved resistance to water infiltration.



B-RUSH C12.5



SMART SYSTEM NEW CX

SMART SYSTEM POWERTUBE 800

SMART SYSTEM PURION 200

29"

12 S



FRAME	Full Carbon Lite frame Toray T800, 29", Integrated battery, Tapered, Internal routing, Rear travel 160 mm, 12x148 mm E-Thru, UDH hanger
FORK	Fox 38 Float Factory eMTB+, Air, GRIPX, 29", Travel 170 mm, 1.5 Tapered, 15x110 mm
REAR SHOCK	Fox Float X2 Factory, EVOL, LSR, HSR, 2 Pos-Lever, 230x65
HEADSET	Acros for Ursa, 1.5", Internal routing
CRANKSET	FSA CK320, FSA 34T MegaTooth
REAR DERAILLEUR	Shimano XT RD-M8100 SGS Shadow Plus, 12s
SHIFTERS LEVERS	Shimano XT SL-M8100 Rapidfire-Plus, 12s
BRAKES	Shimano XT BR-M8120, Four piston, Rotor RT-MT800 203 mm / 203 mm
CASSETTE	Shimano CS-M8100, 12s, 10/51
PEDALS	Alu MTB Full +
WHEELS	RaceFace Turbine eMTB
STEM	RaceFace Turbine-R, Barbore 35 mm, Extension 40 mm
HANDLEBAR	Race Turbine, Length 780 mm, Barbore 35 mm, Rise 40 mm
SEATPOST	Fox Transfer Factory Kashima, Diameter, 31.6 mm, remote
SADDLE	Selle Royal SRX // Whistle performance
TYRES	Schwalbe Tacky Chan EVO, Addix Soft, Super Trail, TLE, 29"x2.40"

MOTOR	Smart System NEW CX, 36 V, 250 W, 2.9 kg
MAX TORQUE	85 Nm
SENSOR TYPE	Torque
BATTERY	Smart System NEW Powertube 800 Horizontal, weight 3.9kg
CHARGER TYPE	4 A
CHARGE TIME	Up to 6.9 hours
MAX ASSISTED SPEED	25 km/h
DISPLAY	Smart System Purion 200
POWER	Eco: 60 % Tour+: 60-340 % EMTB: 140-340 % Turbo: 340 %

BLACK/GOLD

40	0116885400
44	0116885410
48	0116885420
52	0116885430

B-RUSH C11.5



SMART SYSTEM NEW CX

SMART SYSTEM POWERTUBE 800

SMART SYSTEM PURION 200

29"

12 S



FRAME	Full Carbon Lite frame Toray T800, 29", Integrated battery, Tapered, Internal routing, Rear travel 160 mm, 12x148 mm E-Thru, UDH hanger
FORK	Fox 38 Float Factory eMTB+, Air, FIT 4, 29", Travel 160 mm, 1.5 Tapered, 15x110 mm
REAR SHOCK	Fox Float X Performance, EVOL, LSR, HSR, 2 Pos-Lever, 230x65
HEADSET	Acros for Ursa, 1.5", Internal routing
CRANKSET	FSA CK320, FSA 34T MegaTooth
REAR DERAILLEUR	Shimano XT RD-M8100 SGS Shadow Plus, 12s
SHIFTERS LEVERS	Shimano XT SL-M8100 Rapidfire-Plus, 12s
BRAKES	Shimano XT BR-M8120, Four piston, Rotor RT-MT800 203 mm / 203 mm
CASSETTE	Shimano CS-M7100, 12s, 10/51
PEDALS	Alu MTB Full +
WHEELS	Radiate WRS30
STEM	RaceFace Turbine-R, Barbore 35 mm, Extension 40 mm
HANDLEBAR	Race Affect-R, Length 780 mm, Barbore 35 mm, Rise 20 mm
SEATPOST	Dropper A1, Diameter 31.6 mm, remote
SADDLE	Selle Royal SRX // Whistle performance
TYRES	Schwalbe Tacky Chan EVO, Addix Soft, Super Trail, TLE, 29"x2.40"

MOTOR	Smart System NEW CX, 36 V, 250 W, 2.9 kg
MAX TORQUE	85 Nm
SENSOR TYPE	Torque
BATTERY	Smart System NEW Powertube 800 Horizontal, weight 3.9kg
CHARGER TYPE	4 A
CHARGE TIME	Up to 6.9 hours
MAX ASSISTED SPEED	25 km/h
DISPLAY	Smart System Purion 200
POWER	Eco: 60 % Tour+: 60-340 % EMTB: 140-340 % Turbo: 340 %

BLACK/GOLD

40	0116885600
44	0116885610
48	0116885620
52	0116885630

B-RUSH C10.5



SMART SYSTEM NEW CX

SMART SYSTEM POWERTUBE 800

SMART SYSTEM PURION 200

29"

12 S



FRAME	Full Carbon frame Toray T700, 29", Integrated battery, Tapered, Internal routing, Rear travel 160 mm, 12x148 mm E-Thru, UDH hanger
FORK	RockShox ZEB eMTB, Debon Air+, 29", Travel 170 mm, 1.5 Tapered, 15x110 mm
REAR SHOCK	RockShox Super Deluxe, Debon Air Progressive, 230x65
HEADSET	Acros for Ursa, 1.5", Internal routing
CRANKSET	FSA CK320, FSA 34T MegaTooth
REAR DERAILLEUR	Shimano XT RD-M8100 SGS Shadow Plus, 12s
SHIFTERS LEVERS	Shimano SLX SL-M7100 Rapidfire-Plus, 12s
BRAKES	Shimano XT BR-M8120, Four piston, Rotor RT-MT800 203 mm / 203 mm
CASSETTE	Shimano CS-M6100, 12s, 10/51
PEDALS	Alu MTB Full +
WHEELS	Radiate WRS30
STEM	RaceFace Turbine-R, Barbore 35 mm, Extension 40 mm
HANDLEBAR	Race Affect-R, Lenght 780 mm, Barbore 35 mm, Rise 20 mm
SEATPOST	Dropper A1, Diameter 31.6 mm, remote
SADDLE	Selle Royal SRX
TYRES	F: Schwalbe Magic Mary Evo, Addix Soft, Super Trail, 29"x2.60" R: Schwalbe Big Betty EVO, Addix Soft, Super Trail, 29"x2.60"

MOTOR	Smart System NEW CX, 36 V, 250 W, 2.9 kg
MAX TORQUE	85 Nm
SENSOR TYPE	Torque
BATTERY	Smart System NEW Powertube 800 Horizontal, weight 3.9kg
CHARGER TYPE	4 A
CHARGE TIME	Up to 6.9 hours
MAX ASSISTED SPEED	25 km/h
DISPLAY	Smart System Purion 200
POWER	Eco: 60 % Tour+: 60-340 % EMTB: 140-340 % Turbo: 340 %

BLACK/WHITE/GOLD

40	0116885700
44	0116885710
48	0116885720
52	0116885730

B-RUSH C8.4

    29" © 12 S



FRAME	Full Carbon 29", Toray T700, Integrated battery, Tapered, Internal routing, Rear travel 160 mm, 12x148 mm E-Thru
FORK	Fox 36 Float Performance eMTB+, Air, GRIP, 29", Travel 160 mm, 1.5 Tapered, 15x110 mm
REAR SHOCK	Fox Float X Performance, EVOL, LSR, 2 Pos-Lever, 230x65
HEADSET	Acros for Ursa, 1.5", Internal routing
CRANKSET	Miche Black Box, FSA 36T MegaTooth
REAR DERAILLEUR	Shimano XT RD-M8100 SGS Shadow Plus, 12s
SHIFTERS LEVERS	Shimano SLX SL-M7100 Rapidfire-Plus, 12s
BRAKES	Magura MT5, Four piston, Rotor RT30 203 mm / 203 mm
CASSETTE	Shimano CS-M6100, 12s, 10/51
PEDALS	Alu MTB Full +
WHEELS	Mavic E-Crossride 29"
STEM	Satori Ursa, Barbore 35 mm
HANDLEBAR	Alu, 780 mm, Barbore 35 mm, Rise 15 mm
SEATPOST	Dropper Alpha 1, Diameter 31.6 mm, remote
SADDLE	Whistle Performance
TYRES	F: Schwalbe Magic Mary Evo, Addix Soft, Super Trail, 29"x2.60" R: Schwalbe Hans Dampf Evo, Addix Soft, Super Trail, 29"x2.60"

MOTOR	Smart System Performance Line CX, 36 V, 250 W
MAX TORQUE	85 Nm
SENSOR TYPE	Torque
BATTERY	Smart System, Powertube 750 Horizontal, 4.3 kg
CHARGER TYPE	4 A
CHARGE TIME	Up to 6 hours
MAX ASSISTED SPEED	25 km/h
DISPLAY	Smart System Kiox 300 + Led Remote
POWER	Eco: 60 % Tour+: 60-340 % EMTB: 140-340 % Turbo: 340 %

BLACK/RED	
40	0116862200
44	0116862210
48	0116862220
52	0116862230

B-RUSH C8.5



SMART SYSTEM NEW CX

SMART SYSTEM POWERTUBE 800

SMART SYSTEM PURION 200

29"

12 S



FRAME	Full Carbon frame Toray T700, 29", Integrated battery, Tapered, Internal routing, Rear travel 160 mm, 12x148 mm E-Thru, UDH hanger
FORK	RockShox DOMAIN Gold R eMTB, Debon Air, 29", Travel 160 mm, 1.5 Tapered, 15x110 mm
REAR SHOCK	RockShox Deluxe, Debon Air, 230x65
HEADSET	Acros for Ursa, 1.5", Internal routing
CRANKSET	FSA CK320, FSA 34T MegaTooth
REAR DERAILLEUR	Shimano XT RD-M8100 SGS Shadow Plus, 12s
SHIFTERS LEVERS	Shimano Deore SL-M6100 Rapidfire-Plus, 12s
BRAKES	Magura MT5, Four piston, Rotor RT30 203 mm / 203 mm
CASSETTE	Shimano CS-M6100, 12s, 10/51
PEDALS	Alu MTB Full +
FRONT HUB	Shimano TC500B, 15x110, CL, 32h // Glory Wheel, 15x110, CL, 32h
REAR HUB	Shimano TC500B, 12x148, CL, MicroSpline, 32h // Formula, 12x148, CL, MicroSpline, 32h
RIMS	Radiate X30, eDesign Asymmetric, Tubeless Ready, 622x30c
STEM	Alu, Barbore 35 mm, Extension 35 mm
HANDLEBAR	Alu, 780 mm, Barbore 35 mm, Rise 15 mm
SEATPOST	Dropper A1, Diameter 31.6 mm, remote
SADDLE	Selle Royal SRX // Whistle performance
TYRES	F: Schwalbe Magic Mary Evo, Addix Soft, Super Trail, 29"x2.60" R: Schwalbe Big Betty EVO, Addix Soft, Super Trail, 29"x2.60"

MOTOR	Smart System NEW CX, 36 V, 250 W, 2.9 kg
MAX TORQUE	85 Nm
SENSOR TYPE	Torque
BATTERY	Smart System, Powertube 800 Horizontal, 3.9 kg
CHARGER TYPE	4 A
CHARGE TIME	Up to 6.9 hours
MAX ASSISTED SPEED	25 km/h
DISPLAY	Smart System Purion 200
POWER	Eco: 60 % Tour+: 60-340 % EMTB: 140-340 % Turbo: 340 %

BLACK/RED

40	0116885800
44	0116885810
48	0116885820
52	0116885830

B-RUSH C6.4 TRL



SMART SYSTEM PERFORMANCE CX

POWERTUBE 750

SMART SYSTEM PURION200

29" © 12 S



FRAME	Full Carbon 29", Toray T700, Integrated battery, Tapered, Internal routing, Rear travel 160 mm, 12x148 mm E-Thru
FORK	Rock Shox 35 Gold RL e-Bike, DebonAir, Motion Control, Lockout, 29", Travel 150 mm, 1.5 Tapered, Maxle Lite 15x110 mm
REAR SHOCK	Rock Shox Deluxe Select R, DebonAir, 230x65 mm
HEADSET	Acros for Ursa, 1.5", Internal routing
CRANKSET	Sram, 34T X-Sync2
REAR DERAILLEUR	Sram SX Eagle, 12s
SHIFTERS LEVERS	Sram SX Eagle, 12s Single Click Trigger, 12s
BRAKES	Magura MT5, Four piston, Rotor RT30 203 mm / 203 mm
CASSETTE	Sram PG1210 Eagle, 12s, 11/50
PEDALS	Alu MTB Full +
FRONT HUB	Shimano TC500B, 15x110, CL, 32h // Glory Wheel, 15x110, CL, 32h
REAR HUB	Shimano TC500B, 12x148, CL, HG, 32h // Glory Wheel, 12x148, CL, HG, 32h
RIMS	Radiale X30, eDesign Asymmetric, Tubeless Ready, 622x30c
STEM	Satori Ursa, Barbore 35 mm
HANDLEBAR	Alu, 780 mm, Barbore 35 mm, Rise 15 mm
SEATPOST	Dropper Alpha 1, Diameter 31.6 mm, remote
SADDLE	Whistle Performance
TYRES	Schwalbe Nobby Nic, Performance, Addix, 29"x2.60"

MOTOR	Smart System Performance Line CX, 36 V, 250 W
MAX TORQUE	85 Nm
SENSOR TYPE	Torque
BATTERY	Smart System, Powertube 750 Horizontal, 4.3 kg
CHARGER TYPE	4 A
CHARGE TIME	Up to 6 hours
MAX ASSISTED SPEED	25 km/h
DISPLAY	Smart System Kiox 300 + Led Remote
POWER	Eco: 60 % Tour+: 60-340 % EMTB: 140-340 % Turbo: 340 %

BLACK/SILVER

40	0116862400
44	0116862410
48	0116885420
52	0116885430

B-RUSH C4.4



SMART SYSTEM PERFORMANCE CX

POWERTUBE 625

SMART SYSTEM LED REMOTE

29" 12 S



FRAME	Full Carbon 29", Toray T700, Integrated battery, Tapered, Internal routing, Rear travel 160 mm, 12x148 mm E-Thru
FORK	Rock Shox 35 Gold RL e-Bike, DebonAir, Motion Control, Lockout, 29", Travel 150 mm, 1.5 Tapered, Maxle Lite 15x110 mm,
REAR SHOCK	Rock Shox Deluxe Select R, DebonAir, 230x65 mm
HEADSET	Acros for Ursa, 1.5", Internal routing
CRANKSET	FSA, 34T
REAR DERAILLEUR	Shimano Deore RD-M6100 SGS Shadow Plus, 12s
SHIFTERS LEVERS	Shimano Deore SL-M6100 Rapidfire-Plus, 12s
BRAKES	Shimano BR-MT420, Four piston, Rotor SM-RT30 203 mm / 203 mm
CASSETTE	Shimano CS-M6100, 12s, 10/51
PEDALS	Alu MTB Full +
FRONT HUB	Shimano TC500B, 15x110, CL, 32h // Glory Wheel, 15x110, CL, 32h
REAR HUB	Shimano TC500B, 12x148, CL, MicroSpline, 32h // Formula, 12x148, CL, MicroSpline, 32h
RIMS	Radiale X30, eDesign Asymmetric, Tubeless Ready, 622x30c
STEM	Satori Ursa, Barbore 35 mm
HANDLEBAR	Alu, 780 mm, Barbore 35 mm, Rise 15 mm
SEATPOST	Dropper Alpha 1, Diameter 31.6 mm, remote
SADDLE	Whistle Performance
TYRES	Schwalbe Tough Tom 29", 2,6

MOTOR	Smart System Performance Line CX, 36 V, 250 W
MAX TORQUE	85 Nm
SENSOR TYPE	Torque
BATTERY	Smart System, Powertube 625 Horizontal, 3,5 kg
CHARGER TYPE	2A
CHARGE TIME	Up to 9 hours
MAX ASSISTED SPEED	25 km/h
DISPLAY	Smart System Led Remote
POWER	Eco: 60 % Tour+: 60-340 % EMTB: 140-340 % Turbo: 340 %

BLACK/BLACK

44 0116862615

48 0116862625

BLACK/SILVER

40 0116862600

44 0116862610

48 0116885620



E-MTB FULL SUSPENDED

B-RUSH CARBON / ALLOY

Nuove B-Rush con telaio monoscocca in fibra di carbonio Toray T700 e carro in alluminio, più leggero di 3 kg rispetto al telaio e carro in alluminio.

Il giusto compromesso tra peso e prezzo tra un telaio full carbon ed un completamente in alluminio, mantenendo un livello alto e lo stile da competizione che contraddistingue tutte le B-Rush.

New B-Rush with monocoque frame in Toray T700 carbon fiber and aluminum swingarm, 3 kg lighter than the aluminum frame and swingarm.

The right compromise between weight and price between a full carbon frame and a completely aluminum one, maintaining a high level and the racing style that distinguishes all B-Rush.



Nuovo design del telaio che integra l'ammortizzatore. Il telaio è predisposto anche per il Power More Bosch.

New frame design that integrates the shock absorber. The frame is also prepared for the Bosch Power More.



Rocker più leggero, snello ma rigido e sempre su cuscinetti.

Lighter rocker, slim but stiff and always on bearings.

Nuova cover motore, in fibra di carbonio, più leggera e ottimizzata per il raffreddamento necessario per il motore CX (BDU38). Cover predisposta per il BCM Bosch.

New engine cover, in carbon, lighter and optimized for the cooling needed for the CX engine (BDU38). The cover is prepared for the BCM Bosch.



Nuova cover batteria, in fibra di carbonio, alleggerita ma sempre con un alto livello di resistenza a sollecitazioni e urti.

New battery cover, in carbon fiber, lightened but still with a high level of resistance to stress and impacts.



B-RUSH CA6.5



⚙️ SMART SYSTEM NEW CX

🔋 SMART SYSTEM POWERTUBE 800

📺 SMART SYSTEM PURION 200

🛞 29"

⚙️ 12 S



FRAME	Front triangle Carbon Toray T700, Rear triangle Alu, 29", Integrated battery, Tapered, Internal routing, Rear travel 160 mm, 12x148 mm E-Thru, UDH hanger
FORK	RockShox Psylo Silver RC eMTB, Solo Air, 29", Travel 160 mm, 1.5 Tapered, 15x110 mm
REAR SHOCK	RockShox Deluxe, Debon Air, 230x65
HEADSET	Acros for Ursa, 1.5", Internal routing
CRANKSET	FSA CK320, FSA 34T MegaTooth
REAR DERAILLEUR	Shimano XT RD-M8100 SGS Shadow Plus, 12s
SHIFTERS LEVERS	Shimano Deore SL-M6100 Rapidfire-Plus, 12s
BRAKES	Magura MT5, Four piston, Rotor RT30 203 mm / 203 mm
CASSETTE	Shimano CS-M6100, 12s, 10/51
PEDALS	Alu MTB Full +
FRONT HUB	Shimano TC500B, 15x110, CL, 32h // Glory Wheel, 15x110, CL, 32h
REAR HUB	Shimano TC500B, 12x148, CL, HG, 32h // Glory Wheel, 12x148, CL, HG, 32h
RIMS	Radiate X30, eDesign Asymmetric, Tubeless Ready, 622x30c
STEM	Alu, Barbore 35 mm, Extension 35 mm
HANDLEBAR	Alu, 780 mm, Barbore 35 mm, Rise 15 mm
SEATPOST	Dropper A1, Diameter 31.6 mm, remote
SADDLE	Selle Royal SRX // Whistle performance
TYRES	Schwalbe Nobby Nic, Performance, Addix, 29"x2.60"

MOTOR	Smart System NEW CX, 36 V, 250 W, 2.9 kg
MAX TORQUE	85 Nm
SENSOR TYPE	Torque
BATTERY	Smart System NEW Powertube 800 Horizontal, weight 3.9kg
CHARGER TYPE	4 A
CHARGE TIME	Up to 6.9 hours
MAX ASSISTED SPEED	25 km/h
DISPLAY	Smart System Purion 200
POWER	Eco: 60 % Tour+: 60-340 % EMTB: 140-340 % Turbo: 340 %

BLACK/GREEN

40	0116885900
44	0116885910
48	0116885920
52	0116885930

B-RUSH CA5.5



SMART SYSTEM NEW CX

SMART SYSTEM POWERTUBE 800

SMART SYSTEM PURION 200

29"

12 S



FRAME	Front triangle Carbon Toray T700, Rear triangle Alu, 29", Integrated battery, Tapered, Internal routing, Rear travel 160 mm, 12x148 mm E-Thru, UDH hanger
FORK	Suntour ZeronX 36 eMTB, Air RC, 29", Travel 160 mm, 1.5 Tapered, 15x110 mm
REAR SHOCK	RockShox Deluxe, Debon Air, 230x65
HEADSET	Acros for Ursa, 1.5", Internal routing
CRANKSET	FSA CK320, FSA 34T MegaTooth
REAR DERAILLEUR	Shimano Deore RD-M6100 SGS Shadow Plus, 12s
SHIFTERS LEVERS	Shimano Deore SL-M6100 Rapidfire-Plus, 12s
BRAKES	Magura MT5, Four piston, Rotor RT30 203 mm / 203 mm
CASSETTE	Shimano CS-M6100, 12s, 10/51
PEDALS	Alu MTB Full +
FRONT HUB	Shimano TC500B, 15x110, CL, 32h // Glory Wheel, 15x110, CL, 32h
REAR HUB	Shimano TC500B, 12x148, CL, HG, 32h // Glory Wheel, 12x148, CL, HG, 32h
RIMS	Radiate X30, eDesign Asymmetric, Tubeless Ready, 622x30c
STEM	Alu, Barbore 35 mm, Extension 35 mm
HANDLEBAR	Alu, 780 mm, Barbore 35 mm, Rise 15 mm
SEATPOST	Dropper A1, Diameter 31.6 mm, remote
SADDLE	Selle Royal SRX // Whistle performance
TYRES	Schwalbe Nobby Nic, Performance, Addix, 29"x2.60"

MOTOR	Smart System NEW CX, 36 V, 250 W, 2.9 kg
MAX TORQUE	85 Nm
SENSOR TYPE	Torque
BATTERY	Smart System NEW Powertube 800 Horizontal, weight 3.9kg
CHARGER TYPE	4 A
CHARGE TIME	Up to 6.9 hours
MAX ASSISTED SPEED	25 km/h
DISPLAY	Smart System Purion 200
POWER	Eco: 60 % Tour+: 60-340 % EMTB: 140-340 % Turbo: 340 %

BLACK/GREEN

40	0116886000
44	0116886010
48	0116886020
52	0116886030

E-MTB FULL SUSPENDED

S-RUSH C8.4

SHIMANO

EP8

DARFON 720, FRAME TYPE

SC-EM800

29"

12 S



FRAME	Full Carbon 29", Toray T700, integrated battery, Tapered, Rear travel 150 mm, 12x148 mm E-Thru
FORK	Rock Shox Domain RC e-MTB, 150 mm, Maxle Lite 15x110 mm, DebonAir, 1.5 Tapered
REAR SHOCK	Rock Shox RS Deluxe Select R, 230x65
HEADSET	FSA No.57B Tapered 1 1/2
CRANKSET	FSA, 36T MegaTooth
REAR DERAILLEUR	Shimano XT RD-M8100 SGS, Shadow Plus
SHIFTERS LEVERS	Shimano Deore SL-M6100 Rapidfire-Plus, 12s, I-spec
BRAKES	Shimano BR-MT420, Four piston, Rotor SM-RT30 203 mm / 203 mm
CASSETTE	Shimano CS-M6100 12s 10/51
PEDALS	Alu MTB Full +
FRONT HUB	Glory Wheel, 15x110, CL, 32h
REAR HUB	Formula, 12x148, CL, MicroSpline, 32h
RIMS	Radiate X30, eDesign Asymmetric, Tubeless Ready, 622x30c
STEM	Alu Oversize, 35 mm, Bar bore 31,8 mm
HANDLEBAR	Rise Alu Oversize, 780 mm
SEATPOST	Dropper Alpha 1, 31,6 mm, remote
SADDLE	Whistle Performance
TYRES	Schwalbe Tough Tom, 29"x2,6"

MOTOR	EP8, 36 V, 250 W
MAX TORQUE	85 Nm
SENSOR TYPE	Torque
BATTERY	Darfon 720 Wh, frame type, weight 3,8 kg
CHARGER TYPE	4A
CHARGE TIME	Up to 5 hours
MAX ASSISTED SPEED	25 km/h
DISPLAY	SC-EM800
POWER	Eco: 40% Trail: 142% Boost: 350%

Livello assistenza personalizzabile con l'App E-TUBE PROJECT

CARBON /BLUE	
40	0116850900
44	0116850910
48	0116850920
52	0116850930

NEW O-RUSH

Due nuove O-Rush con nuovo telaio con cavi integrati e geometrie Enduro, permettono una guida reattiva e in grado di superare ogni ostacolo.

Per garantire il carattere Enduro della bici i telai sono in accoppiata con il motore OLI Edge da 90 Nm e la nuova batteria Phylion da 840 Wh reali.

Two new O-Rush with new frame with integrated cables and Enduro geometry, allow a reactive ride and able to overcome any obstacle.

To guarantee the Enduro character of the bike, the frames are coupled with the OLI Edge 90 Nm engine and the new Phylion battery with 840 Wh real.

Nuova cover motore in carbonio, più leggera e ottimizzata per il raffreddamento.

New engine cover in carbon, lighter and optimized for the cooling needed.



Nuova cover batteria in carbonio, leggera ma con grande resistenza a sollecitazioni e urti.

New battery cover in carbon, lightweight but with great resistance to stress and impacts.



Rocker più leggero, snello ma rigido e sempre su cuscinetti.

Lighter rocker, slim but stiff and always on bearings.



O-RUSH C8.5



FRAME	Full Carbon frame Toray T700, 29", Integrated battery, Tapered, Internal routing, Rear travel 160 mm, 12x148 mm E-Thru
FORK	RockShox DOMAIN Gold R eMTB, Debon Air, 29", Travel 160 mm, 15 Tapered, 15x110 mm
REAR SHOCK	RockShox Deluxe, Debon Air, 230x65
HEADSET	Acros for Ursa, 1.5", Internal routing
CRANKSET	FSA CK320, FSA 34T
REAR DERAILLEUR	Shimano XT RD-M8100 SGS Shadow Plus, 12s
SHIFTERS LEVERS	Shimano Deore SL-M6100 Rapidfire-Plus, 12s
BRAKES	Magura MT5, Four piston, Rotor RT30 203 mm / 203 mm
CASSETTE	Shimano CS-M6100, 12s, 10/51
PEDALS	Alu MTB Full +
FRONT HUB	Shimano TC500B, 15x110, CL, 32h // Glory Wheel, 15x110, CL, 32h
REAR HUB	Shimano TC500B, 12x148, CL, HG, 32h // Formula, 12x148, CL, MicroSpline, 32h
RIMS	Radiate X30, eDesign Asymmetric, Tubeless Ready, 622x30c
STEM	Alu, Barbore 35 mm, Extension 35 mm
HANDLEBAR	Alu, 780 mm, Barbore 35 mm, Rise 15 mm
SEATPOST	Dropper A1, Diameter 31.6 mm, remote
SADDLE	Selle Royal SRX // Whistle performance
TYRES	F: Schwalbe Magic Mary Evo, Addix Soft, Super Trail, 29"x2.60" R: Schwalbe Big Betty EVO, Addix Soft, Super Trail, 29"x2.60"

MOTOR	OLI Edge, 36 V, 250 W
MAX TORQUE	90 Nm
SENSOR TYPE	Torque
BATTERY	Phylion IT31L 840Wh, weight 3.9 kg
CHARGER TYPE	4A
CHARGE TIME	Up to 6.9 hours
MAX ASSISTED SPEED	25 km/h
DISPLAY	OLI High Vision
POWER	Mode 1: 120% Mode 2: 180% Mode 3: 230% dynamic Mode 4: 400% dynamic

BLACK/RED

40	0116886600
44	0116886610
48	0116886620
52	0116886630

O-RUSH C6.5

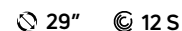

FRAME	Full Carbon frame Toray T700, 29", Integrated battery, Tapered, Internal routing, Rear travel 160 mm, 12x148 mm E-Thru
FORK	Rock Shox 35 Silver TK e-Bike, Solo Air, Lockout, 29", Travel 150 mm, 1.5 Tapered, Maxle Lite 15x110 mm
REAR SHOCK	RockShox Deluxe, Debon Air, 230x65
HEADSET	Acros for Ursa, 1.5", Internal routing
CRANKSET	FSA CK320, FSA 34T
REAR DERAILLEUR	Shimano XT RD-M8100 SGS Shadow Plus, 12s
SHIFTERS LEVERS	Shimano Deore SL-M6100 Rapidfire-Plus, 12s
BRAKES	Magura MT5, Four piston, Rotor RT30 203 mm / 203 mm
CASSETTE	Shimano CS-M6100, 12s, 10/51
PEDALS	Alu MTB Full +
FRONT HUB	Shimano TC500B, 15x110, CL, 32h // Glory Wheel, 15x110, CL, 32h
REAR HUB	Shimano TC500B, 12x148, CL, HG, 32h // Formula, 12x148, CL, MicroSpline, 32h
RIMS	Radiale X30, eDesign Asymmetric, Tubeless Ready, 622x30c
STEM	Alu, Barbore 35 mm, Extension 35 mm
HANDLEBAR	Alu, 780 mm, Barbore 35 mm, Rise 15 mm
SEATPOST	Dropper A1, Diameter 31.6 mm, remote
SADDLE	Selle Royal SRX // Whistle performance
TYRES	Schwalbe Nobby Nic, Performance, Addix, 29"x2.60"

MOTOR	OLI Edge, 36 V, 250 W
MAX TORQUE	90 Nm
SENSOR TYPE	Torque
BATTERY	Phylion IT31L 840Wh, weight 3.9 kg
CHARGER TYPE	4A
CHARGE TIME	Up to 6.9 hours
MAX ASSISTED SPEED	25 km/h
DISPLAY	OLI High Vision
POWER	Mode 1: 120% Mode 2: 180% Mode 3: 230% dynamic Mode 4: 400% dynamic

BLACK/GREEN

40	0116886700
44	0116886710
48	0116886720
52	0116886730

O-RUSH C6.4



FRAME	Full Carbon 29", Toray T700, Integrated battery, Rear travel 150 mm, 12x148 mm E-Thru
FORK	Rock Shox Recon Silver RL, Solo Air, 29", Travel 150 mm, 1.5 Tapered, Maxle Lite 15x110 mm
REAR SHOCK	Rock Shox Deluxe Select R, DebonAir, 230x65 mm
HEADSET	Acros for Ursa, 1.5", Internal routing
CRANKSET	FSA, 34T
REAR DERAILLEUR	Shimano XT RD-M8100 SGS Shadow Plus, 12s
SHIFTERS LEVERS	Shimano Deore SL-M6100 Rapidfire-Plus, 12s
BRAKES	Shimano BR-MT420, Four piston, Rotor SM-RT30 203 mm / 203 mm
CASSETTE	Shimano CS-M6100, 12s, 10/51
PEDALS	Alu MTB Full +
FRONT HUB	Shimano TC500B, 15x110, CL, 32h // Glory Wheel, 15x110, CL, 32h
REAR HUB	Shimano TC500B, 12x148, CL, MicroSpline, 32h // Formula, 12x148, CL, MicroSpline, 32h
RIMS	Radiate X30, eDesign Asymmetric, Tubeless Ready, 622x30c
STEM	Alu, Barbore 31.8 mm
HANDLEBAR	Alu, 780 mm, Barbore 31.8, Rise 15 mm
SEATPOST	Dropper Alpha 1, Diameter 31.6 mm, remote
SADDLE	Whistle Performance
TYRES	Schwalbe Tough Tom, 29"x2,25"

MOTOR	OLI Edge, 36 V, 250 W
MAX TORQUE	90 Nm
SENSOR TYPE	Torque
BATTERY	Phylion BN21L 603Wh, weight 3.6 kg
CHARGER TYPE	2A
CHARGE TIME	Up to 9 hours
MAX ASSISTED SPEED	25 km/h
DISPLAY	OLI High Vision
POWER	Mode 1: 120% Mode 2: 180% Mode 3: 230% dynamic Mode 4: 400% dynamic

BLACK/WHITE

40	0116850950
44	0116850960
48	0116850970
52	0116850980

O-RUSH C4.4

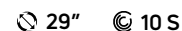

FRAME	Full Carbon 29", Toray T700, Integrated battery, Rear travel 150 mm, 12x148 mm E-Thru
FORK	RST Vibe TNL, Coil, Lockout, 29", Travel 140 mm, 1.5 Tapered, 15x110
REAR SHOCK	Rock Shox Deluxe Select R, DebonAir, 230x65 mm
HEADSET	Acros for Ursa, 1.5", Internal routing
CRANKSET	FSA, 34T
REAR DERAILLEUR	Shimano Deore RD-M5120, Shadow Plus, 10s
SHIFTERS LEVERS	Shimano Deore SL-M4100 Rapidfire-Plus, 10s
BRAKES	Shimano BR-MT200, Rotor SM-RT10 180 mm/180 mm
CASSETTE	Shimano CS-M4100, 10s, 11/46
PEDALS	Alu MTB Full +
FRONT HUB	Shimano TC500B, 15x110, CL, 32h // Glory Wheel, 15x110, CL, 32h
REAR HUB	Shimano TC500B, 12x148, CL, HG, 32h // Formula, 12x148, CL, MicroSpline, 32h
RIMS	Radiate X30, eDesign Asymmetric, Tubeless Ready, 622x30c
STEM	Alu, Barbore 31.8 mm
HANDLEBAR	Alu, 780 mm, Barbore 31.8, Rise 15 mm
SEATPOST	Dropper Alpha 1, Diameter 31.6 mm, remote
SADDLE	Whistle Performance
TYRES	Schwalbe Smart Sam, Performance, Addix, 29"x2.35"

MOTOR	OLI Edge, 36 V, 250 W
MAX TORQUE	90 Nm
SENSOR TYPE	Torque
BATTERY	Phylion IT31L 800Wh, weight 3.9 kg
CHARGER TYPE	4A
CHARGE TIME	Up to 6.9 hours
MAX ASSISTED SPEED	25 km/h
DISPLAY	OLI High Vision
POWER	Mode 1: 120% Mode 2: 180% Mode 3: 230% dynamic Mode 4: 400% dynamic

BLACK/YELLOW

40	0116851000
44	0116851010
48	0116851020
52	0116851030

E-MTB FULL SUSPENDED

B-RUSH ALLOY

Nuova geometrie da competizione, con corsa di 160mm alla forcella e 160 mm al posteriore. Massimo controllo in discesa grazie alla geometria raccolta, pedalabilità in salita assicurata dall'assistenza elettrica.

- **INTEGRAZIONE DELL'AMMORTIZZATORE**
- **ATTACCO UDH**
- **PREDISPOSIZIONE PER RENDERE L'E-BIKE SUV**
- **COVER MOTORE PREDISPOSTA PER BCM BOSCH**
- **PREDISPOSIZIONE PER POWER MORE BOSCH**
- **PORTA DI RICARICA CON CHIUSURA MAGNETICA**

New racing geometry, with 160mm travel at the fork and 160mm at the rear. Maximum downhill control thanks to the collected geometry, uphill rideability ensured by electric assistance.

- **INTEGRATION OF REAR SHOCK**
- **UDH SHIFTER**
- **PREDISPOSITION FOR MAKING THE EBIKE SUV**
- **ENGINE COVER PREPARED FOR BCM BOSCH**
- **PREDISPOSITION FOR POWER MORE BOSCH**
- **CHARGING PORT WITH MAGNETIC CLOSURE**





B-RUSH A8.5



SMART SYSTEM NEW CX

SMART SYSTEM POWERTUBE 800

SMART SYSTEM PURION 200

29"

12 S









FRAME	Full Alu, 29", Integrated battery, Tapered, Internal routing, Rear travel 160 mm, 12x148 mm E-Thru, UDH hanger
FORK	RockShox DOMAIN Gold R eMTB, Debon Air, 29", Travel 160 mm, 15 Tapered, 15x110 mm
REAR SHOCK	RockShox Deluxe, Debon Air, 230x65
HEADSET	Acros for Ursa, 1.5", Internal routing
CRANKSET	FSA CK320, FSA 34T MegaTooth
REAR DERAILLEUR	Shimano XT RD-M8100 SGS Shadow Plus, 12s
SHIFTERS LEVERS	Shimano Deore SL-M6100 Rapidfire-Plus, 12s
BRAKES	Magura MT5, Four piston, Rotor RT30 203 mm / 203 mm
CASSETTE	Shimano CS-M6100, 12s, 10/51
PEDALS	Alu MTB Full +
FRONT HUB	Shimano TC500B, 15x110, CL, 32h // Glory Wheel, 15x110, CL, 32h
REAR HUB	Formula, 12x148, CL, MicroSpline, 32h
RIMS	Radiate X30, eDesign Asymmetric, Tubeless Ready, 622x30c
STEM	Alu, Barbore 35 mm, Extension 35 mm
HANDLEBAR	Alu, 780 mm, Barbore 35 mm, Rise 15 mm
SEATPOST	Dropper A1, Diameter 31.6 mm, remote
SADDLE	Selle Royal SRX // Whistle performance
TYRES	Schwalbe Nobby Nic, Performance, Addix, 29"x2.60"

MOTOR	Smart System NEW CX, 36 V, 250 W, 2.9 kg
MAX TORQUE	85 Nm
SENSOR TYPE	Torque
BATTERY	Smart System NEW Powertube 800 Horizontal, weight 3.9kg
CHARGER TYPE	4 A
CHARGE TIME	Up to 6.9 hours
MAX ASSISTED SPEED	25 km/h
DISPLAY	Smart System Purion 200
POWER	Eco: 60 % Tour+: 60-340 % EMTB: 140-340 % Turbo: 340 %

CHROME/RED

40	0116886100
44	0116886110
48	0116886120
52	0116886130

B-RUSH A7.5

  SMART SYSTEM NEW CX  SMART SYSTEM POWERTUBE 800  SMART SYSTEM PURION 200  29"  12 S









FRAME	Full Alu, 29", Integrated battery, Tapered, Internal routing, Rear travel 160 mm, 12x148 mm E-Thru, UDH hanger
FORK	Suntour ZeronX 36 eMTB, Air RC, 29", Travel 160 mm, 1.5 Tapered, 15x110 mm
REAR SHOCK	RockShox Deluxe, Debon Air, 230x65
HEADSET	Acros for Ursa, 1.5", Internal routing
CRANKSET	FSA CK320, FSA 34T MegaTooth
REAR DERAILLEUR	Shimano Deore RD-M6100 SGS Shadow Plus, 12s
SHIFTERS LEVERS	Shimano Deore SL-M6100 Rapidfire-Plus, 12s
BRAKES	Magura MT5, Four piston, Rotor RT30 203 mm / 203 mm
CASSETTE	Shimano CS-M6100, 12s, 10/51
PEDALS	Alu MTB Full +
FRONT HUB	Shimano TC500B, 15x110, CL, 32h // Glory Wheel, 15x110, CL, 32h
REAR HUB	Shimano TC500B, 12x148, CL, HG, 32h // Formula, 12x148, CL, MicroSpline, 32h
RIMS	Radiate X30, eDesign Asymmetric, Tubeless Ready, 622x30c
STEM	Alu, Barbore 35 mm, Extension 35 mm
HANDLEBAR	Alu, 780 mm, Barbore 35 mm, Rise 15 mm
SEATPOST	Dropper A1, Diameter 31.6 mm, remote
SADDLE	Selle Royal SRX // Whistle performance
TYRES	Schwalbe Nobby Nic, Performance, Addix, 29"x2.60"

MOTOR	Smart System NEW CX, 36 V, 250 W, 2.9 kg
MAX TORQUE	85 Nm
SENSOR TYPE	Torque
BATTERY	Smart System NEW Powertube 800 Horizontal, weight 3.9kg
CHARGER TYPE	4 A
CHARGE TIME	Up to 6.9 hours
MAX ASSISTED SPEED	25 km/h
DISPLAY	Smart System Purion 200
POWER	Eco: 60 % Tour+: 60-340 % EMTB: 140-340 % Turbo: 340 %

CHROME/GREEN

40	0116886200
44	0116886210
48	0116886220
52	0116886230

B-RUSH SUV

 SMART SYSTEM NEW CX
  SMART SYSTEM POWERTUBE 800
  SMART SYSTEM LED REMOTE
  29"
  10 S



FRAME	Full Alu, 29", Integrated battery, Tapered, Internal routing, Rear travel 160 mm, 12x148 mm E-Thru, UDH hanger
FORK	Suntour XCR34, Coil, Lockout, 29", Travel 130 mm, 1.5 Tapered, 15x110 mm
REAR SHOCK	RockShox Deluxe, Debon Air, 230x65
HEADSET	Acros for Ursa, 1.5", Internal routing
CRANKSET	FSA CK320, FSA 34T MegaTooth
REAR DERAILLEUR	Shimano CUES RD-U6000 SGS Shadow Plus, 10s
SHIFTERS LEVERS	Shimano CUES SL-60100 Rapidfire-Plus, 10s
BRAKES	Shimano BR-MT200, Rotor SM-RT10 180 mm/180 mm
CASSETTE	Shimano CS-LG300, 10s, 11/48
PEDALS	Alu MTB Full +
FRONT HUB	Shimano TC500B, 15x110, CL, 32h // Glory Wheel, 15x110, CL, 32h
REAR HUB	Shimano TC500B, 12x148, CL, HG, 32h // Glory Wheel, 12x148, CL, HG, 32h
RIMS	Radiate X30, eDesign Asymmetric, Tubeless Ready, 622x30c
STEM	Alu, Barbore 31.8 mm, Extension 35 mm
HANDLEBAR	Alu, 720 mm, Barbore 31.8 mm, Rise 25 mm
SEATPOST	Dropper A1, Diameter 31.6 mm, remote
SADDLE	Selle Royal SRX // Whistle performance
TYRES	Schwalbe Smart Sam, ctive Line, Addix, 29"x2.40"

MOTOR	Smart System NEW CX, 36 V, 250 W, 2.9 kg
MAX TORQUE	85 Nm
SENSOR TYPE	Torque
BATTERY	Smart System NEW Powertube 800 Horizontal, weight 3.9kg
CHARGER TYPE	2 A
CHARGE TIME	Up to 9.3 hours
MAX ASSISTED SPEED	25 km/h
DISPLAY	Smart System Led Remote
POWER	Eco: 60 % Tour+: 60-340 % EMTB: 140-340 % Turbo: 340 %

MUDGUARDS	SKS A65R
CARRIERS	Alu, without brackets
EXTERNAL LIGHTS	F: Spanninga X&O 30 lux R: Axa Juno LED

CHROME/GREEN

40	0116886400
44	0116886410
48	0116886420
52	0116886430

B-RUSH A4.4



SMART SYSTEM PERFORMANCE CX

POWERTUBE 625

SMART SYSTEM LED REMOTE

29" © 12 S



FRAME	Full Alu, 29", Integrated battery, Tapered, Internal routing, Rear travel 160 mm, 12x148 mm E-Thru, UDH hanger
FORK	RST Vibe TNL, Coil, Lockout, 29", Travel 140 mm, 1.5 Tapered, 15x110
REAR SHOCK	Rock Shox Deluxe Select R, DebonAir, 230x65 mm
HEADSET	Acros for Ursa, 1.5", Internal routing
CRANKSET	FSA, 34T
REAR DERAILLEUR	Shimano CUES RD-U6000 Shadow, 10s
SHIFTERS LEVERS	Shimano CUES SL-U6000 Rapidfire Plus, 10s
BRAKES	Shimano BR-MT420, Four piston, Rotor SM-RT30 203 mm / 203 mm
CASSETTE	Shimano CUES CS-LG300, 10s, 11/48
PEDALS	Alu MTB Full +
FRONT HUB	Shimano TC500B, 15x110, CL, 32h // Glory Wheel, 15x110, CL, 32h
REAR HUB	Shimano TC500B, 12x148, CL, HG, 32h // Glory Wheel, 12x148, CL, HG, 32h
RIMS	Radiate X30, eDesign Asymmetric, Tubeless Ready, 622x30c
STEM	Alu, Barbore 35 mm
HANDLEBAR	Alu, 780 mm, Barbore 35, Rise 15 mm
SEATPOST	Dropper Alpha 1, Diameter 31.6 mm, remote
SADDLE	Whistle Performance
TYRES	Schwalbe Nobby Nic, Performance, Addix, 29"x2.60"

MOTOR	Smart System Performance Line CX, 36 V, 250 W
MAX TORQUE	85 Nm
SENSOR TYPE	Torque
BATTERY	Smart System, Powertube 625 Horizontal, 3.5 kg
CHARGER TYPE	2A
CHARGE TIME	Up to 9 hours
MAX ASSISTED SPEED	25 km/h
DISPLAY	Smart System Led Remote
POWER	Eco: 60 % Tour+: 60-340 % EMTB: 140-340 % Turbo: 340 %

RED	
40	0116871800
44	0116871810
48	0116871820
52	0116871830

B-RUSH A3.4



PERFORMANCE LINE CX

POWERTUBE 625

PURION

29" © 12 S



FRAME	Alu, 29", Hydroformed, Integrated battery, Rear travel 150 mm, 12x148 mm E-Thru
FORK	Rock Shox Recon Silver RL, Solo Air, 29", Travel 150 mm, 1.5 Tapered, Maxle Lite 15x110 mm
REAR SHOCK	Rock Shox Monarch R, SoloAir, 200x57 mm
HEADSET	FSA No.57B tapered 1"1/2
CRANKSET	FSA, 34T, Megatooth
REAR DERAILLEUR	Sram SX Eagle, 12s
SHIFTERS LEVERS	Sram SX Eagle, 12s Single Click Trigger, 12s
BRAKES	Shimano BR-MT420, Four piston, Rotor SM-RT30 203 mm/203 mm
CASSETTE	Sram PG1210 Eagle 12s, 11/50
PEDALS	Alu MTB Full
FRONT HUB	Shimano TC500B, 15x110, CL, 32h // Glory Wheel, 15x110, CL, 32h
REAR HUB	Shimano TC500B, 12x148, CL, HG, 32h // Glory Wheel, 12x148, CL, HG, 32h
RIMS	Radiate X30, eDesign Asymmetric, Tubeless Ready, 622x30c
STEM	Alu, Barbore 35 mm
HANDLEBAR	Alu, 780 mm, Barbore 35, Rise 15 mm
SEATPOST	Dropper Alpha 1, Diameter 31.6 mm, remote
SADDLE	Whistle Performance
TYRES	Schwalbe Nobby Nic, Performance, Addix, 29"x2.60"

MOTOR	Performance CX, 36 V, 250 W
MAX TORQUE	85 Nm
SENSOR TYPE	Torque
BATTERY	Smart System, Powertube 625 Horizontal, 3.5 kg
CHARGER TYPE	2A
CHARGE TIME	Up to 9 hours
MAX ASSISTED SPEED	25 km/h
DISPLAY	Smart System Led Remote
POWER	Eco: 60 % Tour: 140 % EMTB: 140 / 340 % Turbo: 340 %

BLUE/CHROME

40	0116850800
44	0116850810
48	0116850820
52	0116850830

E-MTB FULL SUSPENDED

B-RUSH A5.2X LT12



PERFORMANCE CX CRUISE

POWERTUBE 500

PURION

29" 12 S



FRAME	Alu, 29", Hydroformed, integrated battery, Tapered, Rear travel 150 mm, 12x148 mm
FORK	Rock Shox 35 Silver R, 150 mm, Maxle Lite 15x110 mm, Coil, 1.5 Tapered, E-Bike
REAR SHOCK	DNM A0-38RC, 200x53 mm
HEADSET	FSA No.57B tapered 1 1/2
CRANKSET	FSA, 34T
REAR DERAILLEUR	LT, RD-A12-X, 12s
SHIFTERS LEVERS	LT, SL-A12-X, 12s
BRAKES	Shimano BR-MT200, Rotor SM-RT10 180 mm/180 mm
CASSETTE	LT, CS-A12, 12s, 11-50T
PEDALS	Alu MTB Full
FRONT HUB	Formula CL-811, 15x110, CL, 32h
REAR HUB	Formula CL-3248, 12x148, CL, HG, 32h
RIMS	RADIALE X25, eDesign Asymmetric, Tubeless Ready, 622x25c
STEM	Alu Oversize, 35 mm, Bar bore 31,8 mm
HANDLEBAR	Alu Low Rise, 720 mm
SEATPOST	Alu 30,9 mm
SADDLE	Whistle Performance
TYRES	Schwalbe Smart Sam, Performance, Addix, 29"x2,35"

MOTOR	Performance CX, 36 V, 250 W
MAX TORQUE	85 Nm
SENSOR TYPE	Torque
BATTERY	Smart System, Powertube 500 Horizontal, 2,8 kg
CHARGER TYPE	2A
CHARGE TIME	Up to 9 hours
MAX ASSISTED SPEED	25 km/h
DISPLAY	Smart System Led Remote
POWER	Eco: 60 % Tour: 140 % EMTB: 140 / 340 % Turbo: 340 %

BLACK/ORANGE	
48	0116851125
52	0116851135

O-RUSH A7.5



FRAME	Full Alu, 29", Integrated battery, Tapered, Internal routing, Rear travel 160 mm, 12x148 mm E-Thru, UDH hanger
FORK	Suntour ZeronX 36 eMTB, Air RC, 29", Travel 160 mm, 1.5 Tapered, 15x110 mm
REAR SHOCK	RockShox Deluxe, Debon Air, 230x65
HEADSET	Acros for Ursa, 1.5", Internal routing
CRANKSET	FSA CK320, FSA 34T
REAR DERAILLEUR	Shimano Deore RD-M6100 SGS Shadow Plus, 12s
SHIFTERS LEVERS	Shimano Deore SL-M6100 Rapidfire-Plus, 12s
BRAKES	Magura MT5, Four piston, Rotor RT30 203 mm / 203 mm
CASSETTE	Shimano CS-M6100, 12s, 10/51
PEDALS	Alu MTB Full +
FRONT HUB	Shimano TC500B, 15x110, CL, 32h // Glory Wheel, 15x110, CL, 32h
REAR HUB	Shimano TC500B, 15x110, CL, 32h // Formula, 12x148, CL, MicroSpline, 32h
RIMS	Radiate X30, eDesign Asymmetric, Tubeless Ready, 622x30c
STEM	Alu, Barbore 35 mm, Extension 35 mm
HANDLEBAR	Alu, 780 mm, Barbore 35 mm, Rise 15 mm
SEATPOST	Dropper A1, Diameter 31.6 mm, remote
SADDLE	Selle Royal SRX // Whistle performance
TYRES	Schwalbe Nobby Nic, Performance, Addix, 29"x2.60"

MOTOR	OLI Edge, 36 V, 250 W
MAX TORQUE	90 Nm
SENSOR TYPE	Torque
BATTERY	Phylion IT31L 800Wh, weight 3.9 kg
CHARGER TYPE	4A
CHARGE TIME	Up to 6.9 hours
MAX ASSISTED SPEED	25 km/h
DISPLAY	OLI High Vision
POWER	Mode 1: 120% Mode 2: 180% Mode 3: 230% dynamic Mode 4: 400% dynamic

SILVER

40	0116886800
44	0116886810
48	0116886820
52	0116886830

E-MTB HARDTAIL

Percorsi sterrati, salite da affrontare con agilità, discese impegnative. Le nostre eMTB Hardtail sono perfette per affrontare ogni tipo di trail. Ottime anche nei percorsi urbani ed extra urbani per spostamenti quotidiani.

Dirt roads, climbs to be tackled with agility, challenging descents. Our Hardtail eMTBs are perfect for tackling any type of trail. Also excellent for urban and extra-urban routes for daily commuting.

E-MTB HARDTAIL

B-RACE CARBON

Telaio in carbonio monoscocca con geometrie Hard Tail sportive adatte anche per un utilizzo cittadino su strade sconnesse.

Il telaio monoscocca in carbonio permette di avere come vantaggi:

Leggerezza

La fibra di carbonio è il materiale che offre il miglior rapporto peso/resistenza.

Rigidità

Migliore distribuzione delle forze, aumentando la rigidità e la reattività della bici.

Comfort

Assorbimento delle vibrazioni.

Aerodinamica

Forme più fluide e ottimizzate per ridurre la resistenza con l'aria.

Monocoque carbon frame with sporty Hard Tail geometry also suitable for city use on rough roads.

The monocoque carbon frame allows you to have the following advantages:

Lightness

Carbon fiber is the material that offers the best weight/strength ratio.

Rigidity

Better distribution of forces, increasing the rigidity and reactivity of the bike.

Comfort

Vibration absorption.

Aerodynamics

The monocoque structure allows for more fluid and optimized shapes to reduce air resistance.



Nuova cover motore in carbonio, più leggera e ottimizzata per il raffreddamento. Predisposta per il BCM Bosch.

New engine cover in carbon, lighter and optimized for the cooling needed. It's prepare for BCM Bosch.



Nuova cover batteria in carbonio, leggera ma con grande resistenza a sollecitazioni e urti.

New battery cover in carbon, lightweigh but with great resistance to stres and impacts.



B-RACE C9.4



SMART SYSTEM PERFORMANCE CX

POWERTUBE 750

LED REMOTE + KIOX 300

29" © 12 S



FRAME	Full Carbon 29", Toray T700, Integrated battery, Tapered, Integrated cables, 12x148 mm E-Thru
FORK	RST Vibe TNL, Coil, Lockout, Travel 120 mm, 1.5 Tapered, 15x110 mm
HEADSET	Acros for Viper, 1.5", Internal routing
CRANKSET	FSA, 34T, Megatooth
REAR DERAILLEUR	Shimano XT RD-M8100 SGS Shadow Plus, 12s
SHIFTERS LEVERS	Shimano Deore SL-M6100 Rapidfire-Plus, 12s
BRAKES	Shimano BR-MT420, Four piston, Rotor RT30 203 mm / 203 mm
CASSETTE	Shimano CS-M6100, 12s, 10/51
PEDALS	Alu MTB Full +
FRONT HUB	Shimano TC500B, 15x110, CL, 32h // Glory Wheel, 15x110, CL, 32h
REAR HUB	Shimano TC500B, 12x148, CL, MicroSpline, 32h // Formula, 12x148, CL, MicroSpline, 32h
RIMS	Radiale X30, eDesign Asymmetric, Tubeless Ready, 622x30c
STEM	Satori Viper 0, Barbore 31.8 mm, Internal routing
HANDLEBAR	Alu, 720 mm, Barbore 31.8, Rise 25 mm
SEATPOST	Dropper Alpha 1, Diameter 31.6 mm, remote
SADDLE	Selle Royal Sauris
TYRES	Schwalbe Smart Sam, Performance, Addix, 29"x2.35"

MOTOR	Smart System Performance Line CX, 36 V, 250 W
MAX TORQUE	85 Nm
SENSOR TYPE	Torque
BATTERY	Smart System, Powertube 750 Horizontal, 4.3 kg
CHARGER TYPE	4 A
CHARGE TIME	Up to 9 hours
MAX ASSISTED SPEED	25 km/h
DISPLAY	Smart System Kiox 300 + Led Remote
POWER	Eco: 60 % Tour+: 60-340 % EMTB: 140-340 % Turbo: 340 %

CARBON/ORANGE

41	0116851300
45	0116851310
50	0116851320

B-RACE C8.4



SMART SYSTEM PERFORMANCE CX

POWERTUBE 750

LED REMOTE

29" 12 S



FRAME	Full Carbon 29", Toray T700, Integrated battery, Tapered, Integrated cables, 12x148 mm E-Thru
FORK	RST Vibe TNL, Coil, Lockout, Travel 120 mm, 1.5 Tapered, 15x110 mm
HEADSET	Acros for Viper, 1.5", Internal routing
CRANKSET	FSA, 34T, Megatooth
REAR DERAILLEUR	Shimano Deore RD-M6100 SGS Shadow Plus, 12s
SHIFTERS LEVERS	Shimano Deore SL-M6100 Rapidfire-Plus, 12s
BRAKES	Shimano BR-MT420, Four piston, Rotor SM-RT30 203 mm / 203 mm
CASSETTE	Shimano CS-M6100, 12s, 10/51
PEDALS	Alu MTB Full +
FRONT HUB	Shimano TC500B, 15x110, CL, 32h // Glory Wheel, 15x110, CL, 32h
REAR HUB	Shimano TC500B, 12x148, CL, MicroSpline, 32h // Formula, 12x148, CL, MicroSpline, 32h
RIMS	Radiale X30, eDesign Asymmetric, Tubeless Ready, 622x30c
STEM	Satori Viper 0, Barbore 31.8 mm, Internal routing
HANDLEBAR	Alu, 720 mm, Barbore 31.8, Rise 25 mm
SEATPOST	Dropper Alpha 1, Diameter 31.6 mm, remote
SADDLE	Selle Royal Sauris
TYRES	Schwalbe Smart Sam, Performance, Addix, 29"x2.35"

MOTOR	Smart System Performance Line CX, 36 V, 250 W
MAX TORQUE	85 Nm
SENSOR TYPE	Torque
BATTERY	Smart System, Powertube 750 Horizontal, 4.3 kg
CHARGER TYPE	4 A
CHARGE TIME	Up to 9 hours
MAX ASSISTED SPEED	25 km/h
DISPLAY	Smart System Led Remote
POWER	Eco: 60 % Tour+: 60-340 % EMTB: 140-340 % Turbo: 340 %

CARBON/ORANGE

41	0116851350
45	0116851360
50	0116851370

O-RACE C7.4



EDGE

PHYLION 603WH

OLI HIGH VISION

29"

10 S



FRAME	Full Carbon 29", Toray T700, Integrated battery, Tapered, Integrated cables, 12x148 mm E-Thru
FORK	RST Vibe TNL, Coil, Lockout, Travel 120 mm, 1.5 Tapered, 15x110 mm Sunotur XCR34, Coil, Lockout, Travel 120 mm, 1.5 Tapered, 15x110 mm, remote
HEADSET	Acros for Viper, 1.5", Internal routing
CRANKSET	FSA, 34T, Megatooth
REAR DERAILLEUR	Shimano Deore RD-M5120 SGS Shadow Plus, 10s
SHIFTERS LEVERS	Shimano Deore SL-M4100 Rapidfire-Plus, 10s
BRAKES	Shimano BR-MT200, Rotor SM-RT30 180 mm/180 mm
CASSETTE	Shimano CS-M4100, 10s, 11/46
PEDALS	Alu MTB
FRONT HUB	Shimano TC500B, 15x110, CL, 32h // Glory Wheel, 15x110, CL, 32h
REAR HUB	Shimano TC500B, 12x148, CL, MicroSpline, 32h // Glory Wheel, 12x148, CL, HG, 32h
RIMS	Radiale E25, eBike Ready, Tubeless Ready, 622x25c
STEM	Satori Viper 0, Barbore 31.8 mm, Internal routing
HANDLEBAR	Alu, 720 mm, Barbore 31.8, Rise 25 mm
SEATPOST	Alu 31.6 mm
SADDLE	Selle Royal Sauris
TYRES	Schwalbe Smart Sam, Performance, Addix, 29"x2.35"

MOTOR	OLI Edge, 36 V, 250 W
MAX TORQUE	90 Nm
SENSOR TYPE	Torque
BATTERY	Phylion BN21L 603Wh, weight 3.6 kg
CHARGER TYPE	2A
CHARGE TIME	Up to 9 hours
MAX ASSISTED SPEED	25 km/h
DISPLAY	OLI High Vision
POWER	Mode 1: 120% Mode 2: 180% Mode 3: 230% dynamic Mode 4: 400% dynamic

CARBON/BLUE

40	0116851253
46	0116851263
50	0116851273

CARBON/RED

40	0116851250
46	0116851260
50	0116851270

B-RACE A9.2



PERFORMANCE CX CRUISE

POWERTUBE 625

PURION

29" 12 S



FRAME	Alu 29", Hydroformed, integrated battery, tapered, Internal routing, Forged interface
FORK	Zoom 862 AMS, 100 mm, Coil, 15x100, 1.5 Tapered, Lockout
HEADSET	Acros AZF-575, 1.5", Internal routing
CRANKSET	FSA, 34T, Megatooth
REAR DERAILLEUR	Sram SX Eagle
SHIFTERS LEVERS	Sram SX Eagle Single Click Trigger, 12s
BRAKES	Shimano BR-MT200, Rotor SM-RT10 180 mm/180 mm
CASSETTE	Sram PG1210 Eagle 12s, 11/50
PEDALS	Alu MTB
FRONT HUB	Shimano Alivio MT400, 15x100, CL, 32h
REAR HUB	Shimano TX505, CL, HG, 32h
RIMS	RADIALE E25, eBike Ready, Tubeless Ready, 622x25c
STEM	Satori Viper0, 31,8 mm, Internal routing
HANDLEBAR	Alu Low Rise, 720 mm
SEATPOST	Alu 30,4 mm
SADDLE	Selle Royal Sauris
TYRES	Schwalbe Smart Sam, Performance, Addix, 29"x2,35"

MOTOR	Performance CX 36 V, 250 W
MAX TORQUE	85 Nm
SENSOR TYPE	Torque
BATTERY	Powertube 625 Horizontal, frametype, 3,5 kg
CHARGER TYPE	2 A
CHARGE TIME	Up to 9 hours
MAX ASSISTED SPEED	25 km/h
DISPLAY	PURION
POWER	Eco: 60 % Tour: 140 % EMTB: 140 / 340 % Turbo: 340 %
PETROLEUM/BLACK	
40	0116851200
46	0116851210
50	0116851220

B-RACE A7.2 X5 30.4



PERFORMANCE CX CRUISE

POWERTUBE 500

PURION

29" © 12 S



FRAME	Alu 29", Hydroformed, integrated battery, tapered, Internal routing, Forged interface
FORK	Zoom 869 AMS, 100 mm, 15x100, Coil, Lockout
HEADSET	Acros AZF-576, 1,5", Internal routing
CRANKSET	FSA, 34T
REAR DERAILLEUR	Sram X5, 9s
SHIFTERS LEVERS	Sram X5, Multiple Click Trigger, 9s
BRAKES	Shimano BR-MT200, Rotor SM-RT10 180 mm/180 mm
CASSETTE	Sram PG-920, 9s, 11/34
PEDALS	Alu MTB
FRONT HUB	Shimano TX505, CL, 32h
REAR HUB	Shimano TX505, CL, HG, 32h
RIMS	RADIALE E25, eBike Ready, Tubeless Ready, 622x25c
STEM	Satori Viper0, 31,8 mm, Internal routing
HANDLEBAR	Alu Low Rise, 720 mm
SEATPOST	Alu 30,4 mm
SADDLE	Selle Royal Sauris
TYRES	Vittoria Barzo, 29"x2,35

MOTOR	Performance CX 36 V, 250 W
MAX TORQUE	85 Nm
SENSOR TYPE	Torque
BATTERY	Powertube 500 Horizontal, frametype, 2,8 kg
CHARGER TYPE	4 A
CHARGE TIME	Up to 7,5 hours
MAX ASSISTED SPEED	25 km/h
DISPLAY	PURION
POWER	Eco: 60 % Tour: 140 % EMTB: 140 / 340 % Turbo: 340 %

PETROLEUM/BLACK

40	0116851403
46	0116851413
50	0116851423

B-RACE A8.1 30.4



PERFORMANCE CX CRUISE

POWERTUBE 500

PURION

29" © 12 S



FRAME	Alu 29", hydroformed, integrated battery, tapered, Internal routing, Forged interface
FORK	Suntour XCR32, 100 mm, Coil, Tapered, Lockout
HEADSET	Acros AZF-581, 1,5", Internal routing
CRANKSET	FSA, 34T, Megatooth
REAR DERAILLEUR	Sram SX Eagle
SHIFTERS LEVERS	Sram SX Eagle Single Click Trigger, 12s
BRAKES	Shimano BR-MT200, Rotor SM-RT10 180 mm/180 mm
CASSETTE	Sram PG1210 Eagle 12s, 11/50
PEDALS	Alu MTB
FRONT HUB	Shimano TX505, CL, 32h
REAR HUB	Shimano TX505, CL, HG, 32h
RIMS	RADIALE E25, eBike Ready, Tubeless Ready, 622x25c
STEM	Satori Viper0, 31,8 mm, Internal routing
HANDLEBAR	Alu Low Rise, 720 mm
SEATPOST	Alu 30,4 mm
SADDLE	Selle Royal Sauris
TYRES	Schwalbe Smart Sam, Performance, Addix, 29"x2,35"

MOTOR	Performance CX 36 V, 250 W
MAX TORQUE	85 Nm
SENSOR TYPE	Torque
BATTERY	Powertube 500 Horizontal, frametype, 2,8 kg
CHARGER TYPE	4 A
CHARGE TIME	Up to 7,5 hours
MAX ASSISTED SPEED	25 km/h
DISPLAY	PURION
POWER	Eco: 60 % Tour: 140 % EMTB: 140 / 340 % Turbo: 340 %

GREY/RED	
40	0116832105
46	0116832115
50	0116832125

B-RACE E-BLADE



SMART SYSTEM PERFORMANCE CX

POWERTUBE 500

SMART SYSTEM LED REMOTE

29" 10 S



FRAME	Alu 29", Gravity casting, Integrated battery, Tapered, Internal routing, 12x148 mm E-Thru
FORK	Zoom 860 AMS, Coil, Lockout, 29", Travel 100 mm, QR
HEADSET	Acros for Viper, 1.5", Internal routing
CRANKSET	Miche 34T
REAR DERAILLEUR	Shimano Deore RD-4120 Shadow Plus, 10s
SHIFTERS LEVERS	Shimano Deore SL-M4100 Rapidfire-Plus, 10s
BRAKES	Shimano BR-MT200, Rotor SM-RT10 180 mm/180 mm
CASSETTE	Shimano CS-M4100, 10s, 11/42
PEDALS	Alu MTB
FRONT HUB	Shimano TX505, CL, 32h
REAR HUB	Shimano TC500B, 12x148, CL, HG, 32h // Glory Wheel, 12x148, CL, HG, 32h
RIMS	RADIALE E25, eBike Ready, Tubeless Ready, 622x25c
STEM	Satori Viper 0, Barbore 31.8 mm, Internal routing
HANDLEBAR	Alu, 720 mm, Barbore 31.8, Rise 25 mm
SEATPOST	Alu 31,6 mm
SADDLE	Selle Royal Sauris
TYRES	Vittoria Barzo 29"x2.25"

MOTOR	Smart System Performance CX, 36 V, 250 W
MAX TORQUE	85 Nm
SENSOR TYPE	Torque
BATTERY	Smart System, Powertube 500 Wh, 3,65 kg
CHARGER TYPE	4 A
CHARGE TIME	Up to 7 hours
MAX ASSISTED SPEED	25 km/h
DISPLAY	Smart System Led Remote
POWER	Eco: 60 % Tour: 140 % Sport: 240 % Turbo: 340 %

ANTHRACITE/GOLD

46	0116863705
52	0116863715

B-RACE A6.2



PERFORMANCE CX CRUISE

POWERTUBE 500

PURION

29" 9 S



FRAME	Alu 29", Hydroformed, internal powerpack, Tapered, custom tubing, Internal routing, Forged interface
FORK	Zoom 860 AMS, 100 mm, Coil, Lockout
HEADSET	Acros AZF-576, 1,5", Internal routing
CRANKSET	Miche 34T
REAR DERAILLEUR	Shimano Altus RD-M2000 SGS, Shadow
SHIFTERS LEVERS	Shimano Altus SL-M2010 Rapidfire, 9s
BRAKES	Shimano BR-MT200, Rotor SM-RT10 180 mm/180 mm
CASSETTE	Shimano CS-HG200 9s 11/36
PEDALS	Alu MTB
FRONT HUB	Shimano TX505, CL, 32h
REAR HUB	Shimano TX505, CL, HG, 32h
RIMS	RADIALE E25, eBike Ready, Tubeless Ready, 622x25c
STEM	Satori Viper0, 31,8 mm, Internal routing
HANDLEBAR	Alu Low Rise, 720 mm
SEATPOST	Alu 30,9 mm
SADDLE	Selle Royal Sauris
TYRES	Schwalbe Tough Tom, Active Line, 29"x2,35"

MOTOR	Performance CX 36 V, 250 W
MAX TORQUE	85 Nm
SENSOR TYPE	Torque
BATTERY	Powerpack 500, frametype, 2,6 kg
CHARGER TYPE	2 A
CHARGE TIME	Up to 7 hours
MAX ASSISTED SPEED	25 km/h
DISPLAY	PURION
POWER	Eco: 60 % Tour: 140 % EMTB: 140 / 340 % Turbo: 340 %
PETROLEUM/ORANGE	
46	0116851510

B-RACE A5.4



AM-80

ENERGYTUBE 540

AM LCD FULL-COLOUR

29" 12 S



FRAME	Alu 29", Hydroformed, Integrated battery, Tapered, External routing, Forged interface, QR
FORK	Suntour XCR32, Coil, 29", Travel 100, 1.5 Tapered, QR // Zoom 860 AMS, Travel 100
HEADSET	Acros for Viper, 1.5", Internal routing
CRANKSET	FSA, 34T, Megatooth
REAR DERAILLEUR	Sram SX Eagle
SHIFTERS LEVERS	Sram SX Eagle Single Click Trigger, 12s
BRAKES	Clarks M4, Rotor SM-RT10 180 mm/180 mm
CASSETTE	Sram PG1210 Eagle 12s, 11/50
PEDALS	Alu MTB
FRONT HUB	Shimano TX505, CL, 32h
REAR HUB	Shimano TX505, CL, HG, 32h
RIMS	RADIALE E25, eBike Ready, Tubeless Ready, 622x25c
STEM	Satori Viper 0, Barbore 31.8 mm, Internal routing
HANDLEBAR	Alu, 720 mm, Barbore 31.8, Rise 25 mm
SEATPOST	Alu 30,4 mm
SADDLE	Selle Royal Sauris
TYRES	Schwalbe Smart Sam, Performance, Addix, 29"x2,35" // Vittoria Barzo

MOTOR	AM-80 36 V, 250 W
MAX TORQUE	80 Nm
SENSOR TYPE	Torque
BATTERY	EnergyTube 540, frametype, weight 2.9 kg
CHARGER TYPE	2 A
CHARGE TIME	up to 7 hours
MAX ASSISTED SPEED	25 km/h
DISPLAY	AM LCD ful-colour
POWER	Mode 1: 50% Mode 2: 100% Mode 3: 200% Mode 4: 300% Mode 5: 400%

GREY/NEON RED

46	0116832610
50	0116832620

B-RACE A5.2



AM-80

ENERGYTUBE 540

AM LCD FULL-COLOUR

29" 12 S



FRAME	Alu 29", hydroformed, integrated battery, tapered, Internal routing, Forged interface
FORK	Zoom 860 AMS, 100 mm, Coil, Tapered, Lockout
HEADSET	Acros AZF-575, 1,5", Internal routing
CRANKSET	FSA, 34T, Megatooth
REAR DERAILLEUR	Sram SX Eagle
SHIFTERS LEVERS	Sram SX Eagle Single Click Trigger, 12s
BRAKES	Shimano BR-MT200, Rotor SM-RT10 180 mm/180 mm
CASSETTE	Sram PG1210 Eagle 12s, 11/50
PEDALS	Alu MTB
FRONT HUB	Shimano TX505, CL, 32h
REAR HUB	Shimano TX505, CL, HG, 32h
RIMS	RADIALE E25, eBike Ready, Tubeless Ready, 622x25c
STEM	Satori Viper0, 31,8 mm, Internal routing
HANDLEBAR	Alu Low Rise, 720 mm
SEATPOST	Alu 30,4 mm
SADDLE	Selle Royal Sauris
TYRES	Schwalbe Smart Sam, Performance, Addix, 29"x2,35"

MOTOR	AM-80 36 V, 250 W
MAX TORQUE	80 Nm
SENSOR TYPE	Torque
BATTERY	EnergyTube 540, frametype, weight 2.9 kg
CHARGER TYPE	2 A
CHARGE TIME	up to 7 hours
MAX ASSISTED SPEED	25 km/h
DISPLAY	AM LCD ful-colour
POWER	Mode 1: 50% Mode 2: 100% Mode 3: 200% Mode 4: 300% Mode 5: 400%
GREY/NEON RED	
42	0116832550
46	0116832560
50	0116832570





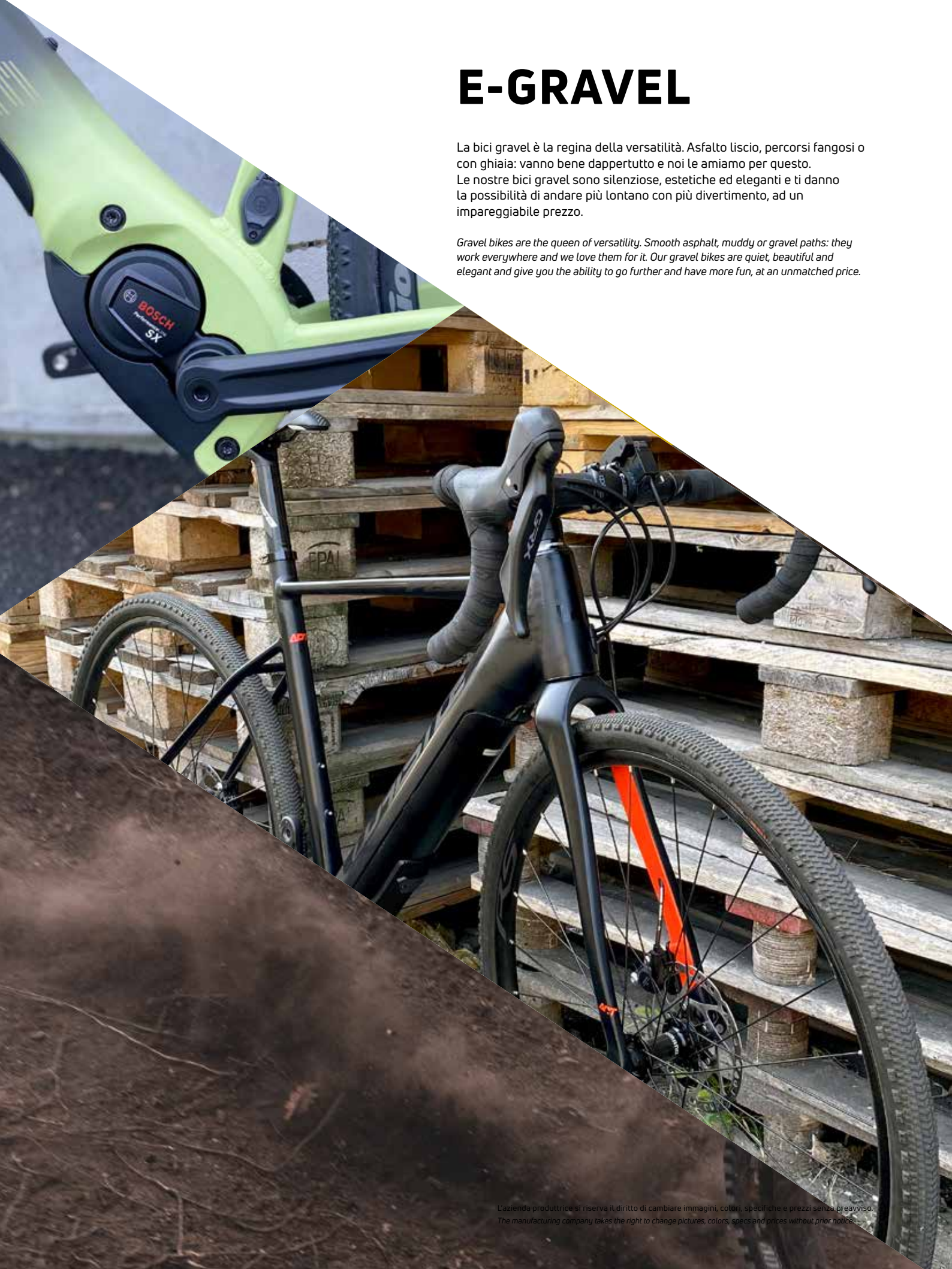

E-GRAVEL

La bici gravel è la regina della versatilità. Asfalto liscio, percorsi fangosi o con ghiaia: vanno bene dappertutto e noi le amiamo per questo. Le nostre bici gravel sono silenziose, estetiche ed eleganti e ti danno la possibilità di andare più lontano con più divertimento, ad un impareggiabile prezzo.

Gravel bikes are the queen of versatility. Smooth asphalt, muddy or gravel paths: they work everywhere and we love them for it. Our gravel bikes are quiet, beautiful and elegant and give you the ability to go further and have more fun, at an unmatched price.



B-KIOWA

 **BOSCH**  SMART SYSTEM PERFORMANCE SX  POWERTUBE 500  SMART SYSTEM MINI REMOTE + SYSTEM CONTROLLER  28"  12.5



FRAME	Alu 700C Integrated battery Internal cable routing 12x148 mm E-Thru Ready for 700x47C
FORK	Full Carbon 12x100 mm thru axle Ready for 700x47C
HEADSET	FSA No.55R 1,5"
CRANKSET	FSA CK320, 34T MegaTooth
REAR DERAILLEUR	Shimano RD-RX822 SGS Shadow Plus, 12s
SHIFTERS LEVERS	Shimano GRX ST-RX820
BRAKES	Shimano GRX BR-RX820, Rotor 160 mm
CASSETTE	Shimano CS-M8100 12s 10/51
PEDALS	Alu Gravel
FRONT HUB	Radiate J100x12, 12x100, 28h
REAR HUB	Radiate J142x12, 12x142, 28h, MS
RIMS	Radiate G 55, eBike Ready, Tubeless Ready, 622x24
STEM	FSA ST-OS-188/SMR, Alu 3D forged, int cables
HANDLEBAR	FSA Adventure AGX Compact, Alu 3D forged, int cables
SEATPOST	Alu 27,2mm
SADDLE	Selle Royal SRX
TYRES	Schwalbe G-One Comp 700x45

MOTOR	Smart System Performance Line SX, 36V, 250 W
MAX TORQUE	55 Nm
SENSOR TYPE	Torque
BATTERY	Smart System, CompactTube 400 Vertical, 2,1 kg
CHARGER TYPE	2A
CHARGE TIME	Up to 6 hours
MAX ASSISTED SPEED	25 km/h
DISPLAY	Smart System Mini Remote + System Controller
POWER	Eco: 60 % Tour+: 60 / 340 % EMTB: 140 / 340 % Turbo: 340 %
BLACK/GREEN MATT	
53	0116882920
56	0116882940



ADVANCED (E)BIKING

Con Fazua siamo riusciti a trovare la perfetta soluzione tra design e performance ed il modello FLOW è l'eBike con motore e batteria invisibili che coniuga le prestazioni di una bici da strada e gravel con l'assistenza del motore.

Grazie al design elegante e integrato non sembra una eBike. Il motore è silenziosissimo e la ruota libera si attiva completamente a velocità sopra i 25 km/ora. Inoltre, è compatibile con le trasmissioni 2x ed è in grado di erogare potenza a sufficienza per salite ripide e tratti controvento.

FAZUA nasce con l'obiettivo di rivoluzionare il mercato proponendo un sistema elettrico che fornisce una sensazione naturale alla pedalata. Il motore è da 250 W, la coppia massima di 60 Nm e la batteria, facilmente removibile con un "click", da 255 Wh.

With Fazua we have managed to find the perfect solution between design and performance and the FLOW model is the eBike with invisible motor and battery that combines the performance of a road and gravel bike with the assistance of the motor.

Thanks to the elegant and integrated design it does not look like an eBike. The motor is very silent and the freewheel is fully activated at speeds above 25 km/h. Furthermore, it is compatible with 2x transmissions and is able to deliver enough power for steep climbs and windy sections.

FAZUA was born with the aim of revolutionizing the market by offering an electric system that provides a natural sensation to pedaling.



BLOCCO MOTORE

Supporto Pedelec - 25 Km/h 250W nominali - fino a 400W 1.9 Kg

DRIVE PACK

Pedelec support - 25 Km/h Nominal 250W - up to 400W 1.9 Kg

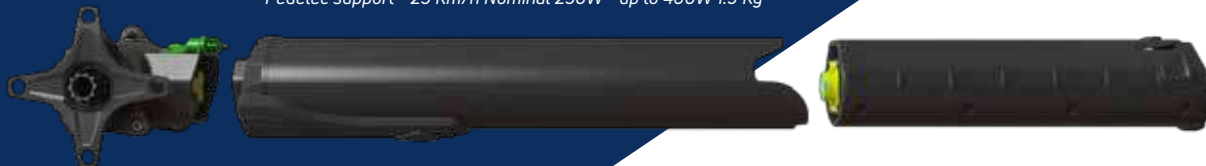

MOVIMENTO CENTRALE

Trasmissione di potenza direttamente alla catena: fino a 60 Nm. Coppia di misurazione utente 1,3 Kg

BOTTOM BRACKET

Power transmission to your chain - up to 60 Nm. User torque measurement 1.3 Kg

BATTERIA SOSTITUIBILE

250Wh - fino a 50Km 36V 1,4 Kg

REPLACEABLE BATTERY

250Wh - fino a 50Km 36V 1,4 Kg



DRIVE UNIT

Estraendo motore e batteria con un semplice "click", Flow può essere utilizzata come bicicletta da corsa tradizionale senza alcuna resistenza alla pedalata. È disponibile una cover per nascondere il vuoto lasciato da batteria e motore.

The drivepack can be added and removed with one "click" and allows a quick switch from a bike to a pedelec whenever you like. An additional cover is available to hide the empty space left by the drivepack once removed.

1 DRIVEPACK 250 W - 1,92 kg

Unità motore rimovibile

Removable motor unit

2 BATTERY PACK 36V - 1,38 kg

Batteria agli ioni sostituibile

Replaceable Li-on battery pack

3 BOTTOM BRACKET 60 Nm - 1,31 kg

4 REMOTE CONTROL Bluetooth ready

3 livelli di supporto

3 support modes

FLOW ADVENTURE E2.0



⚙️ RIDE 50 EVATION

🔋 EVATION 255 WH

📺 RMT

🛞 28" © 11 S



FRAME	Alu, Hydroformed, Smooth welding, Flat mount disc brake, Tapered, 12x142 mm
FORK	Carbon monocoque, Tapered, 12x100 mm, Flat mount disc brake
HEADSET	FSA No.57E tapered 1"1/2
CRANKSET	FSA CK-746, 40T
REAR DERAILLEUR	Shimano GRX RD-RX812, 11s
SHIFTERS LEVERS	Shimano GRX ST-RX600, 1x11s
BRAKES	Shimano GRX BR-RX400, Rotor SM-RT64 160 mm/160 mm
CASSETTE	Shimano CS-M8000, 11s 11/42
WHEELS	Shimano WH-RS370
STEM	FSA ST-OS 97
HANDLEBAR	FSA NS Adventure Compact
SEATPOST	FSA Energy SBS
SADDLE	Selle Italia Model X
TYRES	Schwalbe G-One Bite, 700x40

MOTOR	Fazua Ride 50 Evation, 36V, 250W
MAX TORQUE	55 Nm
SENSOR TYPE	Torque
BATTERY	Fazua Energy 250x, weight 1,38 kg
CHARGER TYPE	2 A
CHARGE TIME	Up to 3,5 hours
MAX ASSISTED SPEED	25 km/h
DISPLAY	RMT
POWER	Breeze: 75 % River: 150 % Rocket: 240 %

BLACK/RED

54	0116820800
58	0116820810

FLOW ADVENTURE RIDE



⚙️ RIDE 50 EVATION

🔋 EVATION 255 WH

📺 RMT RX

🛞 28" 🌀 11 S



FRAME	Alu, Hydroformed, Smooth welding, Flat mount disc brake, Tapered, 12x142 mm
FORK	Carbon monocoque, Tapered, 12x100 mm, Flat mount disc brake
HEADSET	FSA No.57E tapered 1"1/2
CRANKSET	FSA CK-746, 40T
REAR DERAILLEUR	Shimano GRX RD-RX812, 11s
SHIFTERS LEVERS	Shimano GRX ST-RX600, 1x11s
BRAKES	Shimano GRX BR-RX400, Rotor SM-RT64 160 mm/160 mm
CASSETTE	Shimano CS-M7000, 11s, 11/42
WHEELS	Shimano WH-RS370
STEM	FSA ST-OS 97
HANDLEBAR	FSA NS Adventure Compact
SEATPOST	FSA Energy SBS
SADDLE	Selle Italia Model X
TYRES	Schwalbe G-One Bite, 700x40

MOTOR	Fazua Ride 50 Evation, 36V, 250W
MAX TORQUE	55 Nm
SENSOR TYPE	Torque
BATTERY	Fazua Energy 250x, weight 1,38 kg
CHARGER TYPE	2 A
CHARGE TIME	Up to 3,5 hours
MAX ASSISTED SPEED	25 km/h
DISPLAY	RMT RX
POWER	Breeze: 75 % River: 150 % Rocket: 240 %

BLACK/RED

54

0116820700



E-URBAN

Bici da città adatte per lunghe e corte percorrenze, confortevole design, motore potente e batteria con lunga autonomia.

City bikes suitable for long and short distances, comfortable design, powerful engine and battery with long autonomy.



E-TREKKING | E-URBAN

SPEED URBAN

Telaio in carbonio monoscocca con predisposizione per due batterie, da 625 Wh nel tubo diagonale e 500 Wh nel tubo superiore.

Forcella rigida, cover motore, cover batteria e carter sono anch'essi in carbonio. Il telaio è in versione uomo e donna con geometrie adatte per lunghe percorrenze, su strade urbane o fuori strada.

Il telaio monoscocca in carbonio permette di avere come vantaggi:

Leggerezza

La fibra di carbonio è il materiale che offre il miglior rapporto peso/resistenza.

Rigidità

Migliore distribuzione delle forze, aumentando la rigidità e la reattività della bici.

Comfort

Assorbimento delle vibrazioni.

Aerodinamica

Forme più fluide e ottimizzate per ridurre la resistenza con l'aria.

Monocoque carbon frame with provision for two batteries, 625 Wh in the diagonal tube and 500 Wh in the upper tube.

Rigid fork, engine cover, battery cover and crankcase are also in carbon.

The frame is available in a men's and women's version with geometries suitable for long distances and urban or off-road roads.

The monocoque carbon frame allows you to have the following advantages:

Lightness

Carbon fiber is the material that offers the best weight/strength ratio.

Rigidity

Better distribution of forces, increasing the rigidity and reactivity of the bike.

Comfort

Vibration absorption.

Aerodynamics

The monocoque structure allows for more fluid and optimized shapes to reduce air resistance.





SPEED URBAN C9.1 LOCK



PERFORMANCE CX CRUISE

POWERTUBE 500 & 625

KIOX

29"

12 S



FRAME	Full Carbon 29", Toray T700, dual integrated battery, oversize head tube, 12x148 mm E-Thru
FORK	Carbon, Tapered 1"1/2, 15x110
HEADSET	Acros AZF-581, 1,5", Internal routing
CRANKSET	FSA, 38T, MegaTooth
REAR DERAILLEUR	Shimano XT RD-M8100 SGS, Shadow Plus
SHIFTERS LEVERS	Shimano Deore SL-M6100 Rapidfire-Plus, 12s
BRAKES	Shimano BR-MT420, Four piston, Rotor SM-RT30 203 mm/203 mm
CASSETTE	Shimano CS-M6100 12s 10/51
PEDALS	Alu TKK
FRONT HUB	Shimano Alivio MT400, 15x110, CL, 32h
REAR HUB	Shimano Alivio MT410, 12x148, CL, MicroSpline, 32h
RIMS	Radiale X25, 25x622, eBike ready, Asymmetric
STEM	Satori Viper0, 31,8 mm, Internal routing
HANDLEBAR	Alu Low Rise, 720 mm
SEATPOST	Alu 31,6 mm
SADDLE	Selle Royal Essenza Moderate
TYRES	Schwalbe Energizer Plus, Performance, GreenGuard, TwinSkin, 700x55

MOTOR	Performance CX 36 V, 250 W
MAX TORQUE	85 Nm
SENSOR TYPE	Torque
BATTERY	Powertube 500 Horizontal & Powertube 625 Horizontal
CHARGER TYPE	4 A
CHARGE TIME	Up to 9,4 hours
MAX ASSISTED SPEED	25 km/h
DISPLAY	KIOX
POWER	Eco: 60 % Tour: 140 % EMTB: 140 / 340 % Turbo: 340 %
MUDGUARDS	SKS A65R
CHAINCOVER	FSA Bash
CARRIERS	Alu, without brackets
EXTERNAL LIGHTS	F: Supernova Mini2 R: Axa BlueLine LED Lightguide

BLACK/ANTHRACITE MATT

48	0116832815
52	0116832825

SPEED URBAN C9.2



PERFORMANCE CX CRUISE

POWERTUBE 500 & 625

INTUVIA

29"

12 S



FRAME	Full Carbon 29"; Toray T700, dual integrated battery, oversize head tube, 12x148 mm E-Thru
FORK	RST Vibe, 100 mm, Air
HEADSET	Acros AZF-576, 1,5", Internal routing
CRANKSET	FSA, 38T, MegaTooth
REAR DERAILLEUR	Shimano XT RD-M8100 SGS, Shadow Plus
SHIFTERS LEVERS	Shimano Deore SL-M6100 Rapidfire-Plus, 12s
BRAKES	Shimano BR-MT420, Four piston, Rotor SM-RT30 203 mm/203 mm
CASSETTE	Shimano CS-M6100 12s 10/51
PEDALS	Alu TKK
FRONT HUB	Shimano Alivio MT400, 15x110, CL, 32h
REAR HUB	Shimano Alivio MT410, 12x148, CL, MicroSpline, 32h
RIMS	Radiale X25, 25x622, eBike ready, Asymmetric
STEM	Satori Viper0, 31,8 mm, Internal routing
HANDLEBAR	Alu Low Rise, 720 mm
SEATPOST	Alu 31,6 mm
SADDLE	Selle Royal Essenza Moderate
TYRES	Schwalbe Energizer Plus, Performance, GreenGuard, TwinSkin, 700x55

MOTOR	Performance CX 36 V, 250 W
MAX TORQUE	85 Nm
SENSOR TYPE	Torque
BATTERY	Powertube 500 Horizontal & Powertube 625 Horizontal
CHARGER TYPE	4 A
CHARGE TIME	Up to 9,4 hours
MAX ASSISTED SPEED	25 km/h
DISPLAY	Intuvia
POWER	Eco: 60 % Tour: 140 % EMTB: 140 / 340 % Turbo: 340 %
MUDGUARDS	SKS A65R
CHAINCOVER	FSA Bash
CARRIERS	Alu, without XLCets
EXTERNAL LIGHTS	F: Supernova Mini2 R: Axa BlueLine LED Lightguide

BLACK/ANTHRACITE MATT

48	0116851800
52	0116851810

SPEED URBAN C8.1 LOCK MAN



PERFORMANCE CX CRUISE

POWERTUBE 500 & 625

INTUVIA

29"

12 S



FRAME	Full Carbon 29", Toray T700, dual integrated battery, oversize head tube, 12x148 mm E-Thru
FORK	Rock Shox 35 Silver R, 100 mm, Maxle Lite 15x110 mm, Coil, Tapered, Lockout, E-Bike
HEADSET	Acros AZF-576, 1,5", Internal routing
CRANKSET	FSA, 38T, MegaTooth
REAR DERAILLEUR	Sram SX Eagle
SHIFTERS LEVERS	Sram SX Eagle Single Click Trigger, 12s
BRAKES	Shimano BR-MT420, Four piston, Rotor SM-RT30 203 mm/180 mm
CASSETTE	Sram PG1210 Eagle 12s, 11/50
PEDALS	Alu MTB
FRONT HUB	Shimano Alivio MT400, 15x110, CL, 32h
REAR HUB	Shimano Alivio MT400, 12x148, CL, HG, 32h
RIMS	RADIALE X25, eDesign Asymmetric, Tubeless Ready, 622x25c
STEM	Satori Viper0, 31,8 mm, Internal routing
HANDLEBAR	Alu Low Rise, 720 mm
SEATPOST	Alu 31,6 mm
SADDLE	Selle Royal Essenza Moderate
TYRES	Schwalbe Smart Sam, K-Guard, 29"x2,35"

MOTOR	Performance CX 36 V, 250 W
MAX TORQUE	85 Nm
SENSOR TYPE	Torque
BATTERY	Powertube 500 Horizontal & Powertube 625 Horizontal
CHARGER TYPE	4 A
CHARGE TIME	Up to 9,4 hours
MAX ASSISTED SPEED	25 km/h
DISPLAY	INTUVIA
POWER	Eco: 60 % Tour: 140 % EMTB: 140 / 340 % Turbo: 340 %
MUDGUARDS	SKS A65R
CHAINCOVER	FSA Bash
CARRIERS	Alu, without XLCets
EXTERNAL LIGHTS	F: Supernova Mini2 R: Axa BlueLine LED Lightguide

BLACK/ANTHRACITE MATT

Man 52

0116832925

SPEED URBAN C8.1 LOCK LADY



PERFORMANCE CX CRUISE

POWERTUBE 500 & 625

INTUVIA

29"

12 S



FRAME	Full Carbon 29"; Toray T700, dual integrated battery, oversize head tube, 12x148 mm E-Thru
FORK	Rock Shox 35 Silver R, 100 mm, Maxle Lite 15x110 mm, Coil, Tapered, Lockout, E-Bike
HEADSET	Acros AZF-576, 1,5", Internal routing
CRANKSET	FSA, 38T, MegaTooth
REAR DERAILLEUR	Sram SX Eagle
SHIFTERS LEVERS	Sram SX Eagle Single Click Trigger, 12s
BRAKES	Shimano BR-MT420, Four piston, Rotor SM-RT30 203 mm/180 mm
CASSETTE	Sram PG1210 Eagle 12s, 11/50
PEDALS	Alu MTB
FRONT HUB	Shimano Alivio MT400, 15x110, CL, 32h
REAR HUB	Shimano Alivio MT400, 12x148, CL, HG, 32h
RIMS	RADIALE X25, eDesign Asymmetric, Tubeless Ready, 622x25c
STEM	Satori Viper0, 31,8 mm, Internal routing
HANDLEBAR	Alu Low Rise, 720 mm
SEATPOST	Alu 31,6 mm
SADDLE	Selle Royal Essenza Moderate
TYRES	Schwalbe Smart Sam, K-Guard, 29"x2,35"

MOTOR	Performance CX 36 V, 250 W
MAX TORQUE	85 Nm
SENSOR TYPE	Torque
BATTERY	Powertube 500 Horizontal & Powertube 625 Horizontal
CHARGER TYPE	4 A
CHARGE TIME	Up to 9,4 hours
MAX ASSISTED SPEED	25 km/h
DISPLAY	INTUVIA
POWER	Eco: 60 % Tour: 140 % EMTB: 140 / 340 % Turbo: 340 %
MUDGUARDS	SKS A65R
CHAINCOVER	FSA Bash
CARRIERS	Alu, without XLCets
EXTERNAL LIGHTS	F: Supernova Mini2 R: Axa BlueLine LED Lightguide

BLACK/ANTHRACITE MATT

Lady 44

0116832905

SPEED URBAN C8.1 MAN



PERFORMANCE CX CRUISE

POWERTUBE 500 & 625

INTUVIA

29"

12 S



FRAME	Full Carbon 29", Toray T700, dual integrated battery, oversize head tube, 12x148 mm E-Thru
FORK	Rock Shox 35 Silver R, 100 mm, Maxle Lite 15x110 mm, Coil, Tapered, Lockout, E-Bike
HEADSET	Acros AZF-576, 1,5", Internal routing
CRANKSET	FSA, 38T, MegaTooth
REAR DERAILLEUR	Sram SX Eagle
SHIFTERS LEVERS	Sram SX Eagle Single Click Trigger, 12s
BRAKES	Shimano BR-MT420, Four piston, Rotor SM-RT30 203 mm/180 mm
CASSETTE	Sram PG1210 Eagle 12s, 11/50
PEDALS	Alu MTB
FRONT HUB	Shimano Alivio MT400, 15x110, CL, 32h
REAR HUB	Shimano Alivio MT400, 12x148, CL, HG, 32h
RIMS	RADIALE X25, eDesign Asymmetric, Tubeless Ready, 622x25c
STEM	Satori Viper0, 31,8 mm, Internal routing
HANDLEBAR	Alu Low Rise, 720 mm
SEATPOST	Alu 31,6 mm
SADDLE	Selle Royal Essenza Moderate
TYRES	Schwalbe Smart Sam, K-Guard, 29"x2,35"

MOTOR	Performance CX 36 V, 250 W
MAX TORQUE	85 Nm
SENSOR TYPE	Torque
BATTERY	Powertube 500 Horizontal & Powertube 625 Horizontal
CHARGER TYPE	4 A
CHARGE TIME	Up to 9,4 hours
MAX ASSISTED SPEED	25 km/h
DISPLAY	PURION
POWER	Eco: 60 % Tour: 140 % EMTB: 140 / 340 % Turbo: 340 %
MUDGUARDS	SKS A65R
CHAINCOVER	FSA Bash
CARRIERS	Alu, without XLCets
EXTERNAL LIGHTS	F: Supernova Mini2 R: Axa BlueLine LED Lightguide

BLACK/ANTHRACITE MATT

Man 48

0116832910

SPEED URBAN C8.1 LADY



PERFORMANCE CX CRUISE

POWERTUBE 500 & 625

INTUVIA

29"

12 S



FRAME	Full Carbon 29", Toray T700, dual integrated battery, oversize head tube, 12x148 mm E-Thru
FORK	Rock Shox 35 Silver R, 100 mm, Maxle Lite 15x110 mm, Coil, Tapered, Lockout, E-Bike
HEADSET	Acros AZF-576, 1,5", Internal routing
CRANKSET	FSA, 38T, MegaTooth
REAR DERAILLEUR	Sram SX Eagle
SHIFTERS LEVERS	Sram SX Eagle Single Click Trigger, 12s
BRAKES	Shimano BR-MT420, Four piston, Rotor SM-RT30 203 mm/180 mm
CASSETTE	Sram PG1210 Eagle 12s, 11/50
PEDALS	Alu MTB
FRONT HUB	Shimano Alivio MT400, 15x110, CL, 32h
REAR HUB	Shimano Alivio MT400, 12x148, CL, HG, 32h
RIMS	RADIALE X25, eDesign Asymmetric, Tubeless Ready, 622x25c
STEM	Satori Viper0, 31,8 mm, Internal routing
HANDLEBAR	Alu Low Rise, 720 mm
SEATPOST	Alu 31,6 mm
SADDLE	Selle Royal Essenza Moderate
TYRES	Schwalbe Smart Sam, K-Guard, 29"x2,35"

MOTOR	Performance CX 36 V, 250 W
MAX TORQUE	85 Nm
SENSOR TYPE	Torque
BATTERY	Powertube 500 Horizontal & Powertube 625 Horizontal
CHARGER TYPE	4 A
CHARGE TIME	Up to 9,4 hours
MAX ASSISTED SPEED	25 km/h
DISPLAY	PURION
POWER	Eco: 60 % Tour: 140 % EMTB: 140 / 340 % Turbo: 340 %
MUDGUARDS	SKS A65R
CHAINCOVER	FSA Bash
CARRIERS	Alu, without XLCets
EXTERNAL LIGHTS	F: Supernova Mini2 R: Axa BlueLine LED Lightguide

BLACK/ANTHRACITE MATT

Lady 44

0116832900

SPEED URBAN C8.4 MAN



PERFORMANCE LINE CX

POWERTUBE 625

KIOX

29"

12 S



FRAME	Full Carbon 29", Toray T700, Dual Integrated battery, Tapered Internal routing, 12x148 mm E-Thru
FORK	Zoom 860S, Coil, Lockout, 29", Travel 100 mm, QR
HEADSET	Acros for Viper, 1,5", Internal routing
CRANKSET	FSA, 38T, MegaTooth
REAR DERAILLEUR	Sram SX Eagle, 12s
SHIFTERS LEVERS	Sram SX Eagle, 12s Single Click Trigger, 12s
BRAKES	Shimano BR-MT200, Rotor SM-RT10 180 mm/180 mm
CASSETTE	Sram PG1210 Eagle 12s, 11/50
PEDALS	Alu TTK
FRONT HUB	Shimano TX505, CL, 32h
REAR HUB	Shimano TC500B, 12x148, CL, HG, 32h // Glory Wheel, 12x148, CL, HG, 32h
RIMS	Radiale X25, eDesign Asymmetric, Tubeless Ready, 622x25c
STEM	Satori Viper 0, Barbore 31.8 mm, Internal routing
HANDLEBAR	Alu, 720 mm, Barbore 31.8, Rise 25 mm
SEATPOST	Alu 31.6 mm
SADDLE	Selle Royal Essenza
TYRES	Vittoria Barzo, 29"x2,25"

MOTOR	Performance CX 36 V, 250 W
MAX TORQUE	85 Nm
SENSOR TYPE	Torque
BATTERY	PT 625 Horizontal & Predisposition for PT 500 Horizontal
CHARGER TYPE	4 A
CHARGE TIME	Up to 9 hours
MAX ASSISTED SPEED	25 km/h
DISPLAY	KIOX
POWER	Eco: 55 % Tour: 120 % Sport: 200 % Turbo: 300 %
MUDGUARDS	SKS A65R
CHAINCOVER	FSA Bash
CARRIERS	Alu, without brackets
EXTERNAL LIGHTS	F: Herrmans MR GO – 120 lumen R: Axa BlueLine LED Lightguide

BLACK/GREEN

Man 48

0116866510

SPEED URBAN C7.2 SX LOCK



PERFORMANCE CX CRUISE

POWERTUBE 625

PURION

28"

12 S



FRAME	Full Carbon 29", Toray T700, dual integrated battery, oversize head tube, 12x148 mm E-Thru
FORK	Zoom 860S, Coil, Lockout, 29", Travel 100 mm, QR
HEADSET	Acros for Viper, 1,5", Internal routing
CRANKSET	FSA, 38T, MegaTooth
REAR DERAILLEUR	Sram SX Eagle, 12s
SHIFTERS LEVERS	Sram SX Eagle, 12s Single Click Trigger, 12s
BRAKES	Shimano BR-MT200, Rotor SM-RT10 180 mm/180 mm
CASSETTE	Sram PG1210 Eagle 12s, 11/50
PEDALS	Alu TTK
FRONT HUB	Shimano TX505, CL, 32h
REAR HUB	Shimano TC500B, 12x148, CL, HG, 32h // Glory Wheel, 12x148, CL, HG, 32h
RIMS	Radiale X25, eDesign Asymmetric, Tubeless Ready, 622x25c
STEM	Satori Viper 0, Barbore 31.8 mm, Internal routing
HANDLEBAR	Alu, 720 mm, Barbore 31.8, Rise 25 mm
SEATPOST	Alu 31.6 mm
SADDLE	Selle Royal Essenza
TYRES	Vittoria Barzo, 29"x2,25"

MOTOR	Performance CX 36 V, 250 W
MAX TORQUE	85 Nm
SENSOR TYPE	Torque
BATTERY	PT 625 Horizontal & Predisposition for PT 500 Horizontal
CHARGER TYPE	4 A
CHARGE TIME	Up to 9 hours
MAX ASSISTED SPEED	25 km/h
DISPLAY	PURION
POWER	Eco: 55 % Tour: 120 % Sport: 200 % Turbo: 300 %
MUDGUARDS	SKS A65R
CHAINCOVER	FSA Bash
CARRIERS	Alu, without brackets
EXTERNAL LIGHTS	F: Herrmans MR GO – 120 lumen R: Axa BlueLine LED Lightguide

BLACK/GREEN

48	0116851917
52	0116851927

B-RACE SUV



AM-80

ENERGYTUBE 500

AM LCD FULL-COLOUR

29" 12 S



FRAME	Alu 29", hydroformed, integrated battery, tapered, Internal routing, Forged interface
FORK	Zoom 860 AMS, 100 mm, Coil, Tapered, Lockout
HEADSET	Acros AZF-575, 1,5", Internal routing
CRANKSET	FSA, 34T, Megatooth
REAR DERAILLEUR	Sram SX Eagle
SHIFTERS LEVERS	Sram SX Eagle Single Click Trigger, 12s
BRAKES	Shimano BR-MT200, Rotor SM-RT10 180 mm/180 mm
CASSETTE	Sram PG1210 Eagle 12s, 11/50
PEDALS	Alu MTB
FRONT HUB	Shimano TX505, CL, 32h
REAR HUB	Shimano TX505, CL, HG, 32h
RIMS	RADIALE E25, eBike Ready, Tubeless Ready, 622x25c
STEM	Satori Viper0, 31,8 mm, Internal routing
HANDLEBAR	Alu Low Rise, 720 mm
SEATPOST	Alu 30,4 mm
SADDLE	Selle Royal Sauris
TYRES	Schwalbe Smart Sam, Performance, Addix, 29"x2,35"
MUDGUARDS	SKS A65R
CARRIERS	Alu, without brackets

MOTOR	AM-80 36 V, 250 W
MAX TORQUE	80 Nm
SENSOR TYPE	Torque
BATTERY	EnergyTube 500, frametype, weight 2.9 kg
CHARGER TYPE	2 A
CHARGE TIME	up to 7 hours
MAX ASSISTED SPEED	25 km/h
DISPLAY	AM LCD ful-colour
POWER	Mode 1: 50% Mode 2: 100% Mode 3: 200% Mode 4: 300% Mode 5: 400%

GREY/NEON RED

42	0116832555
46	0116832565
50	0116832575





BOSCH

NEW CX (BDU38)

NEW PERFORMANCE LINE CX (BDU384)

Performance Line CX (BDU384) porta la dinamica di guida e l'agilità a un nuovo livello. È potente, leggero e silenzioso.

La drive unit fa esattamente ciò che si desidera, in modo sensibile, controllato e diretto. Offre una sensazione di pedalata naturale.

COPPIA MASSIMA 85 Nm

SUPPORTO MASSIMO 340%

NEW PERFORMANCE LINE CX (BDU384)

The Performance Line CX (BDU384) takes riding dynamics and agility to a new level. It is powerful, light and quiet.

The drive unit does exactly what you want, sensitively, controlled and direct. It offers a natural riding sensation.

MAXIMUM TORQUE 85 Nm

MAXIMUM SUPPORT 340%



NEW POWERTUBE

Per maggior esigenze in termini di potenza e stile: le batterie PowerTube garantiscono alto potenziale energetico durante ogni tour e, grazie alle dimensioni compatte e alla forma minimalista, si integrano perfette col design dell'eBike.

Un fermo ne impedisce la caduta tuttavia, anche se è presente, le batterie possono comunque essere rimosse in modo semplice e pratico.

I nuovi PowerTube nel sistema intelligente sono disponibili in due versioni: 800 Wh, 600 Wh. I nostri telai sono già predisposti per tutte e tre le batterie. Questo significa che sarai pronto per ogni esigenza, sia per le brevi distanze in città, sia per la guida sportiva di una eMTB.

For higher demands in terms of power and style: PowerTube batteries guarantee high energy potential on every tour and, thanks to their compact dimensions and minimalist shape, they integrate perfectly into the design of the eBike.

A lock prevents them from falling out, but even if it is present, the batteries can still be removed easily and conveniently.

The new PowerTubes in the intelligent Bosch system are available in two versions: 800 Wh, 600 Wh. Our frames are already prepared for all three batteries.

This means that you are prepared for every requirement, whether for short distances in the city or for sporty riding of an eMTB.



CHARGER

Un solo carica batterie leggero (800gr) e compatto per PowerTube e PowerPack da 4 A o 2 A.

Il carica batterie del Sistema Intelligente non è compatibile con il sistema Bosch eBike 2.

A single lightweight (800 gr) and compact battery charger for PowerTube and PowerPack 4 A or 2 A.

The Intelligent System battery charger is not compatible with the Bosch eBike 2 system.

THE SMART SYSTEM

The smart
system



PERFORMANCE LINE CX (BDU374)

La Performance Line CX (BDU374Y) è un sistema di trazione potente e dinamico, che garantisce facilità di utilizzo e una sensazione di pedalata unica. Va al limite insieme a te, per un divertimento ancora maggiore su terreni tecnicamente impegnativi.

COPPIA MASSIMA 85 Nm

SUPPORTO MASSIMO 340%

The Performance Line CX (BDU374Y) is a powerful and dynamic drive system that guarantees ease of use and a unique riding sensation. It goes to the limit with you, for even more fun on technically challenging terrain.

MAXIMUM TORQUE 85 Nm

MAXIMUM SUPPORT 340%



PERFORMANCE LINE (BDU336)

Versatile e silenziosa, anche la Performance Line fa ora parte del sistema intelligente. Approfitta dei vantaggi, resta in movimento e continua a esplorare i dintorni. Nonostante il potente supporto, la drive unit offre una sensazione di pedalata naturale e più sicurezza.

COPPIA MASSIMA 75 Nm

SUPPORTO MASSIMO 340%

Versatile and quiet, the Performance Line is now also part of the intelligent system. Enjoy the benefits, stay on the move and continue to explore the surroundings. Despite the powerful support, the drive unit offers a natural riding sensation and more safety.

MAXIMUM TORQUE 75 Nm

MAXIMUM SUPPORT 340%



ACTIVE LINE (BDU332)

Al lavoro la mattina e al ristorante la sera: con Active Line, pedalare è divertente. È silenziosissima e fornisce un supporto armonico, pertanto è ideale per i percorsi in città. L'accelerazione finemente dosata e la resistenza alla pedalata appena percepibile oltre i 25 km/h o in modalità Off rendono ogni pedalata rilassante, trasformandola in una breve attività nel tempo libero, persino nel traffico all'ora di punta.

COPPIA MASSIMA 40 Nm

SUPPORTO MASSIMO 340%

At work in the morning and in the restaurant in the evening: with the Active Line, cycling is fun. It is whisper-quiet and provides harmonious support, making it ideal for city riding. The finely dosed acceleration and barely noticeable pedal resistance above 25 km/h or in Off mode make every ride relaxing and a short leisure activity, even in rush hour traffic.

MAXIMUM TORQUE 40 Nm

MAXIMUM SUPPORT 340%

POWERTUBE

Fonte di energia versatili: le PowerPack Frame sono installate all'esterno del telaio nel punto più vicino al baricentro della bicicletta. Hanno un'impugnatura con la quale puoi rimuoverle facilmente e trasportarle comodamente.

Sono disponibili in tre versioni: 545 Wh, 400Wh e 300 Wh. Tutte le PowerPack nel sistema intelligente hanno lo stesso supporto. Quindi puoi inserire facilmente una nuova batteria se la geometria dell'eBike lo consente. Con una batteria più piccola riduci il peso, con una più grande aumenti l'autonomia.

Versatile energy sources: The Frame PowerPacks are installed on the outside of the frame at the point closest to the bike's center of gravity. They have a handle that allows you to easily remove them and carry them comfortably.

They are available in three versions: 545 Wh, 400 Wh and 300 Wh. All PowerPacks in the intelligent system have the same holder. This means you can easily insert a new battery if the geometry of the eBike allows it. With a smaller battery you reduce the weight, with a larger one you increase the range.

POWERPACK

Per maggior esigenze in termini di potenza e stile: le PowerPack garantiscono alto potenziale energetico durante ogni tour e, grazie alle dimensioni compatte e alla forma minimalista, si integrano perfette col design dell'eBike. Un fermo ne impedisce la caduta tuttavia, anche se è presente, le batterie possono comunque essere rimosse in modo semplice e pratico.

I PowerTube nel sistema intelligente di Bosch sono disponibili in tre versioni: 750 Wh, 625 Wh e 500 Wh. I nostri telai sono già predisposti per tutte e tre le batterie. Questo significa che sarai pronto per ogni esigenza, sia per le brevi distanze in città, sia per la guida sportiva di una eMTB.

For higher demands in terms of power and style: PowerTubes guarantee high energy potential on every tour and, thanks to their compact dimensions and minimalist shape, integrate perfectly into the design of the eBike.

A lock prevents them from falling out, but even if it is present, the batteries can still be removed easily and conveniently.

The PowerTubes in the intelligent Bosch system are available in three versions: 750 Wh, 625 Wh and 500 Wh. Our frames are already prepared for all three batteries. This means that you are prepared for every requirement, whether for short distances in the city or for sporty riding of an eMTB.

CHARGER

Un carica batterie leggero (800gr) e compatto per PowerTube e PowerPack da 4 A o 2 A.

Il carica batterie del Sistema Intelligente non è compatibile con il sistema Bosch eBike 2.

A single lightweight (800gr) and compact battery charger for PowerTube and PowerPack 4 A or 2 A. The Intelligent System battery charger is not compatible with the Bosch eBike 2 system.



POWERMORE 250

Batteria supplementare portatile, grande come una borraccia, che garantisce ulteriore autonomia. Compatto e con soli 1,5kg, Range Extender può essere fissato facilmente al porta borraccia ed è combinabile con tutte le batterie del sistema intelligente. Informati in anticipo per sapere se puoi utilizzarlo sulla tua eBike.

Portable, water bottle-sized supplementary battery that provides additional autonomy. Compact and weighing only 1.5kg, the Range Extender can be easily attached to the water bottle holder and can be combined with all intelligent system batteries. Find out in advance whether you can use it on your eBike.



	POWERTUBE 800	POWERTUBE 600	POWERTUBE 750	POWERTUBE 625	POWERTUBE 500	POWERPACK 400
TENSIONE Voltage	36 V	36 V	36 V	36 V	36 V	36 V
KG TELAIO Frame	3,9 kg	3,0 kg	4,3 kg	3,6 kg	3,0 kg	2,2 kg
RICARICA Charge	6,9 h	5,3 h	6 h	5,4 h	4,5 h	3,5 h

*con il Fast Charger da 6 A *with the 6A Fast Charger

THE E-BIKE2 SYSTEM

PERFORMANCE LINE CX

Compatta, leggera e più potente, combina a materiali di alta qualità, una trazione estremamente potente e sensori di fascia alta. In questo modo l'eMountain biking sul trail assume una dimensione completamente nuova. Con una coppia fino a 85 Nm, feature nei comandi del motore e una modalità eMTB evoluta, la Performance Line CX offre un'esperienza di marcia emozionante: naturale, intuitiva, potente.

COPPIA MASSIMA 85 Nm

SUPPORTO MASSIMO 340%

Compact, lightweight and more powerful, it combines high-quality materials, an extremely powerful drive and high-end sensors. This takes eMountain biking on the trail to a whole new dimension. With up to 85 Nm of torque, features in the motor control and an advanced eMTB mode, the Performance Line CX offers an emotional riding experience: natural, intuitive, powerful.

MAXIMUM TORQUE 85 Nm

MAXIMUM SUPPORT 340%



PERFORMANCE LINE

Sistema di trazione versatile, per fare sport nel verde, andare al lavoro o rilassarsi durante il tempo libero, fornisce il giusto supporto sempre al momento giusto. Disponibili due versioni. La versione Cruise silenziosa e leggera garantisce il supporto fino a 25km/h con una coppia massima di 65Nm, apprezzata per la sensazione di pedalata naturale e sportiva, assicurando divertimento anche su terreni mossi.

COPPIA MASSIMA 65 Nm

SUPPORTO MASSIMO 300%

Versatile traction system, for doing sports in the countryside, going to work or relaxing during your free time, provides the right support always at the right time. Two versions available. The silent and lightweight Cruise version guarantees support up to 25km/h with a maximum torque of 65Nm, appreciated for the natural and sporty pedaling sensation, ensuring fun even on rough terrain.

MAXIMUM TORQUE 65 Nm

MAXIMUM SUPPORT 300%



ACTIVE LINE PLUS

Ideale per gli spostamenti quotidiani e per le uscite non programmate. Silenziosa, piccola ma potente, offre maggior divertimento. Niente più fastidioso rumore di sottofondo e una resistenza alla pedalata appena percepibile oltre i 25 km/h: fare nuove esperienze e scoperte diventa più semplice.

COPPIA MASSIMA 50 Nm

SUPPORTO MASSIMO 270%

Ideal for daily commutes and unplanned outings. Silent, small but powerful, it offers more fun. No more annoying background noise and barely perceptible pedal resistance above 25 km/h: new experiences and discoveries become easier.

MAXIMUM TORQUE 50 Nm

MAXIMUM SUPPORT 270%



ACTIVE LINE

Per andare in ufficio al mattino o per il tempo libero, con la Active Line muoversi nel traffico della città è un divertimento. Armonica, leggera e silenziosa, è ideale per tutti i percorsi cittadini. Accelerazione dosata in modo armonico e resistenza alla pedalata appena percepibile oltre i 25km/h o in modalità off.

COPPIA MASSIMA 40 Nm

SUPPORTO MASSIMO 260%

Whether you're going to the office in the morning or spending your free time, the Active Line makes moving through city traffic a pleasure. Harmonious, light and silent, it's ideal for all city routes. Harmoniously dosed acceleration and barely noticeable pedal resistance above 25km/h or in off mode.

MAXIMUM TORQUE 40 Nm

MAXIMUM SUPPORT 260%



POWERTUBE

Fonte di energia versatili: le PowerPack Frame sono installate all'esterno del telaio nel punto più vicino al baricentro della bicicletta. Hanno un'impugnatura con la quale puoi rimuoverle facilmente e trasportarle comodamente.

Sono disponibili in tre versioni: 545 Wh, 400Wh e 300 Wh. Tutte le PowerPack nel sistema intelligente hanno lo stesso supporto. Quindi puoi inserire facilmente una nuova batteria se la geometria dell'eBike lo consente. Con una batteria più piccola riduci il peso, con una più grande aumenti l'autonomia.

Versatile energy sources: The Frame PowerPacks are installed on the outside of the frame at the point closest to the bike's center of gravity. They have a handle that allows you to easily remove them and carry them comfortably.

They are available in three versions: 545 Wh, 400 Wh and 300 Wh. All PowerPacks in the intelligent system have the same holder. This means you can easily insert a new battery if the geometry of the eBike allows it. With a smaller battery you reduce the weight, with a larger one you increase the range.



POWERPACK

Per maggior esigenze in termini di potenza e stile: le PowerTube garantiscono alto potenziale energetico durante ogni tour e, grazie alle dimensioni compatte e alla forma minimalista, si integrano perfette col design dell'eBike. Un fermo ne impedisce la caduta tuttavia, anche se è presente, le batterie possono comunque essere rimosse in modo semplice e pratico.

I PowerTube nel sistema intelligente di Bosch sono disponibili in tre versioni: 750 Wh, 625 Wh e 500 Wh. I nostri telai sono già predisposti per tutte e tre le batterie. Questo significa che sarai pronto per ogni esigenza, sia per le brevi distanze in città, sia per la guida sportiva di una eMTB.

For higher demands in terms of power and style: PowerTubes guarantee high energy potential on every tour and, thanks to their compact dimensions and minimalist shape, integrate perfectly into the design of the eBike.

A lock prevents them from falling out, but even if it is present, the batteries can still be removed easily and conveniently.

The PowerTubes in the intelligent Bosch system are available in three versions: 750 Wh, 625 Wh and 500 Wh. Our frames are already prepared for all three batteries. This means that you are prepared for every requirement, whether for short distances in the city or for sporty riding of an eMTB.



CHARGER

Un carica batterie leggero (800gr) e compatto per PowerTube e PowerPack da 4 A o 2 A.

Il carica batterie del Sistema Intelligente non è compatibile con il sistema Bosch eBike 2.

A single lightweight (800gr) and compact battery charger for PowerTube and PowerPack 4 A or 2 A.

The Intelligent System battery charger is not compatible with the Bosch eBike 2 system.



	POWERTUBE 400	POWERTUBE 500	POWERTUBE 625	POWERPACK 300	POWERPACK 400	POWERPACK 500
TENSIONE <i>Voltage</i>	36 V	36 V	36 V	36 V	36 V	36 V
KG TELAIO <i>Frame</i>	2,9 kg	2,8 kg	3,5 kg	2,5 kg	2,5 kg	2,5 kg
RICARICA <i>Charge</i>	2,5 h	3 h	3,7 h	2,5 h	2,5 h	2,5 h

*con il Fast Charger da 6 A *with the 6A Fast Charger

INTUVIA

Praticità e controllo della tua ebike garantiti: il display è sempre ben visibile in qualsiasi situazione e mostra tutte le informazioni importanti. Il ciclo-computer viene controllato in modo intuitivo dall'unità di comando separata, così le mani restano sul manubrio.

Easy and intuitive control of your eBike guaranteed: the display is easy to read in any situation and shows you all the important information. The separate control unit allows you to keep your hands safely on the handlebar.



PURION

Concentratevi sulle informazioni essenziali e visualizzatele solo con un clic del pollice: il ciclocomputer Purion è sinonimo di efficienza e precisione massime.

You can focus on the essentials and get all important information at a click of your thumb: the Purion on-board computer operates with maximum efficiency and precision.



PURION 200

Unità di comando con display a colori compatto e completamente connessa al sistema intelligente. Questa soluzione all-in-one, che rende il manubrio più ordinato, viene posizionata direttamente vicino al pollice e offre una visualizzazione nitida dei dati di marcia e un controllo semplice ed ergonomico di tutte le funzioni dell'eBike. Combina Purion 200 con un display aggiuntivo per un ulteriore comfort.

Control unit with compact colour display and fully networked in the smart system. The all-in-one solution ensures an uncluttered handlebar, is in close proximity to the thumb and offers a razor-sharp display of ride data as well as simple, ergonomic control of all eBike functions. Combine the Purion 200 with an additional display – for even greater convenience.



LED REMOTE

Il LED Remote collega l'eBike all'app eBike Flow. Consente di accedere facilmente a tutti i dati di guida importanti ed è intuitivo; le mani restano sul manubrio in modo sicuro. Cambia le modalità di marcia, usa la camminata assistita e aziona il display o il Ride screen del tuo smartphone. Grazie al sistema intelligente, il LED Remote ti consente di effettuare in modo autonomo gli aggiornamenti per l'eBike.

The LED Remote connects your eBike with the eBike Flow app. It makes it easy to access all important ride data and is intuitive to use - your hands remain safely on the handlebars. Change riding modes, use the smart walk assistance function and operate your display or the ride screen on your smartphone. Thanks to the smart system, the LED Remote allows you to perform updates for your eBike for yourself.



KIOX

Il design si fonde con la funzionalità: il ciclo-computer Kiox è appositamente studiato per le esigenze dei ciclisti sportivi ambiziosi. Robusto, piccolo e compatto, Kiox è l'accompagnatore perfetto, sia fuoristrada che come partner per l'allenamento.

The LED Remote connects your eBike with the eBike Flow app. It makes it easy to access all important ride data and Design meets functionality: the Kiox on-board computer was specially developed for the needs of ambitious riders. Robust and small, the compact Kiox is the perfect companion - whether used off-road or as a partner in training.



KIOX 300

Robusto e intelligente, Kiox 300 è il display per il sistema intelligente che ti accompagnerà nei tuoi spostamenti. Può essere controllato in modo intuitivo tramite l'unità di comando, compatto e protetto da getti d'acqua e da polvere. Il display a colori è leggibile in modo ottimale. Il display ideale per le avventure sportive e i tour più impegnativi.

The Kiox 300 is display for the smart system, and are your robust, intelligent companions. It can be intuitively controlled from the control unit, is compact and protected from splashing water and dust. The color display is optimally readable. The display is ideal for sporting adventures and challenging rides.



DUAL BATTERY

Nessuna meta è troppo lontana: DualBattery è la soluzione perfetta per amanti dei tour, pendolari che percorrono lunghi tragitti e guidatori di mezzi di carico o eMountain biker.

Il sistema Dual Battery è presente su tutti i nostri modelli Speed Urban.

No journey is too long: DualBattery is the perfect solution for touring eBikers, long-distance commuters, cargo eBikers and eMountain bikers.

The Dual Battery system is present on all our Speed Urban models.



CONNECT MODULE

Il ConnectModule è il componente hardware necessario per poter utilizzare il servizio eBike Alarm e aumentare così la protezione da furto. È dotato di sensori di movimento, di un modulo GPS e di una batteria propria. L'eBike Alarm funziona così anche senza la batteria eBike. Con l'aiuto dei sensori, il ConnectModule montato sotto il coperchio del motore può identificare i movimenti dell'eBike e attivare un allarme locale. Informati in anticipo per sapere se puoi utilizzare il Connect Module sulla tua eBike.

Solo per bici con il sistema intelligente.

The ConnectModule is the hardware component required to use the eBike Alarm service and thus increase theft protection. It is equipped with motion sensors, a GPS module and its own battery. The eBike Alarm thus also works without an eBike battery. With the help of sensors, the ConnectModule mounted under the engine cover can identify movements of the eBike and trigger a local alarm. Find out in advance whether you can use the Connect Module on your eBike.

Only for bikes with the intelligent system.

FLOW APP

L'app eBike Flow è il fulcro sistema intelligente di Bosch e ti offre un'esperienza di guida migliore e connessa: più sicura, più personalizzata e più confortevole.

Nel sistema intelligente, la drive unit è completamente collegata in rete con gli altri componenti della tua eBike. Con l'app eBike Flow, è possibile utilizzare funzioni digitali come l'activity-tracking, l'eBike Lock, aggiornare e personalizzare e la tua eBike.

L'applicazione è disponibile per App Store e Google Play. Una volta scaricata collega tua eBike!

Visita il sito Bosch eBike per tenerti aggiornate su tutte le novità.

Solo per bici con il sistema intelligente.

The eBike Flow app is the heart of Bosch's intelligent system and offers you a better and more connected riding experience: safer, more personalized and more comfortable.

In the intelligent system, the drive unit is fully networked with the other components of your eBike. With the eBike Flow app, you can use digital functions such as activity tracking, eBike Lock, update and personalize your eBike.

The application is available for the App Store and Google Play. Once downloaded, connect your eBike!

Visit the Bosch eBike website to stay up to date with all the latest news.

Only for bikes with the intelligent system.



ASSISTENZA

Per richiedere modifiche della configurazione della eBike con il sistema Bosch eBike 2 ed il sistema intelligente usa il nuovo programma Bosch Diagnostic Tool 3.

Sarà molto più facile e veloce richiedere assistenza grazie al cloud di Bosch per cui avverrà tutto da remoto.

To request changes to the eBike configuration with the Bosch eBike 2 system and the intelligent system use the new Bosch Diagnostic Tool 3 program.

It will be much easier and faster to request assistance thanks to the Bosch cloud so everything will happen remotely.





UNA POTENZA UNICA, CON CONTROLLO PERFEZIONATO

Motore compatto e leggero con coppia di 90 Nm adatto ad uso intensivo in fuori strada, offre una sensazione di pedalata naturale ed è adattato a superare ogni difficoltà.

Alla gamma O-Rush e O-Race arriva la nuova Phylion BN31L con 800 Wh REAL! Questo nuovo progetto sviluppato con Phylion, aziende leader nel settore, consente ampia autonomia e riduzione di peso grazie alle nuove celle 21700 ad alta capacità specifica.

4 settaggi del motore tra cui scegliere, ciascuno con 4 livelli di assistenza:

- Originale, scelto da noi pensato apposta per le nostre eBike
- Eco, predilige l'autonomia della batteria
- Comfort, giusto rapporto tra autonomia della batteria e potenza del motore
- Power, eroga la massima potenza del motore

POWER UNDER FINE-TUNED CONTROL

Compact and lightweight motor with 90 Nm torque suitable for intensive off-road use, offers a natural pedaling sensation and is adapted to overcome any difficulty.

The new Phylion BN31L with 800 Wh REAL arrives to the O-Rush and O-Race range! This new project developed with Phylion, leading companies in the sector, allows for ample autonomy and weight reduction thanks to the new 21700 cells with high specific capacity.

4 engine settings to choose from, each with 4 levels of assistance:

- Original, chosen by us specifically designed for our eBikes
- Eco, favors battery autonomy
- Comfort, the right balance between battery autonomy and engine power
- Power, delivers maximum engine power



DISPLAY HIGH VISION

Display da 2" ad alta definizione con Gorilla-Glass, per uno schermo anti-riflesso e regolazione automatica della luce, racchiuso in un design sottile ed elegante.

Ricco di molte informazioni come ad esempio la potenza espressa dal biker.

2" high definition display with Gorilla-Glass, for an anti-glare screen and automatic light adjustment, enclosed in a thin and elegant design. Packed with lots of information such as the power expressed by the biker.



O-RUSH A7.5

MOTOR	OLI Edge, 36 V, 250 W
MAX TORQUE	90 Nm
SENSOR TYPE	Torque
BATTERY	Phylion IT31L 840Wh, weight 3.9 kg
CHARGER TYPE	4A
CHARGE TIME	Up to 6.9 hours
MAX ASSISTED SPEED	25 km/h
DISPLAY	OLI High Vision
POWER	Mode 1: 120% Mode 2: 180% Mode 3: 230% dynamic Mode 4: 400% dynamic

SHIMANO

EP8

IL NUOVO KIT PER GLI E-BIKER SPORTIVI

Affronta le salite più ripide e i tracciati più impegnativi con la massima fiducia, grazie alla coppia massima di 85 Nm. Fornisce potenza fluida e diretta per essere certi di avere sempre il controllo completo, sperimentando una sensazione di guida naturale.

THE NEW KIT FOR SPORTY E-BIKER

Tackle steep climbs and tough trails with full confidence thanks to 85Nm maximum torque. The drive unit delivers smooth, direct power to ensure you're always in complete control while experiencing a natural ride feeling.



DISPLAY SC-EM80

Visualizza le impostazioni di sistema, i livelli di servoassistenza e i dati di guida con uno schermo LCD a colori da 1,6" di facile consultazione in corsa.

- La posizione di montaggio elegante e integrata favorisce la visibilità
- Posizionamento sicuro sul manubrio
- Elegante estetica di alta gamma
- Leggibilità anche in pieno sole
- Collegamento wireless all'App E-TUBE PROJECT Cyclist Cyclist o E-TUBE RIDE

View your system settings, assist levels and ride metrics via a 1.6 (inch) color LCD screen for easy on-trail reference.

- Streamlined mount position provides easy visibility
- Positioned safely on handlebar
- Premium, elegant aesthetics
- Readable in bright sunshine
- Connect wirelessly to the E-TUBE PROJECT Cyclist Cyclist or E-TUBE RIDE app

S-RUSH C8.4

MOTOR	EP8, 36 V, 250 W
MAX TORQUE	85 Nm
SENSOR TYPE	Torque
BATTERY	Darfon 720 Wh, frame type, weight 3,8 kg
CHARGER TYPE	4A
CHARGE TIME	Up to 5 hours
MAX ASSISTED SPEED	25 km/h
DISPLAY	SC-EM800
POWER	Eco: 40% Trail: 142% Boost: 350%





MTB FULL SUSPENDED

Tecnologie recenti e innovative abbinate a telai di ultimissima generazione per affrontare percorsi sempre più tecnici e sfidanti. MTB versatili e piacevoli da guidare con geometrie sempre più aggressive in ottica racing.

Recent and innovative technologies combined with the latest generation of frames to face increasingly technical and challenging trails. MTB versatile and pleasant to drive with more aggressive geometries for racing.



MTB FULL SUSPENDED

CHEYENNE E COMANCHE

Due geometrie Enduro diverse ma con un unico obiettivo: una bici reattiva in curva, leggera e divertente da guidare.
Forcella con escursione da 160mm o 150mm ed escursione al posteriore da 150mm.

Il telaio monoscocca in carbonio permette di avere come vantaggi:

Leggerezza

La fibra di carbonio è il materiale che offre il miglior rapporto peso/resistenza.

Rigidità

Migliore distribuzione delle forze, aumentando la rigidità e la reattività della bici.

Comfort

Assorbimento delle vibrazioni.

Aerodinamica

Forme più fluide e ottimizzate per ridurre la resistenza con l'aria.

*Two different Enduro geometries but with one goal: a bike that is responsive in curves, light and fun to ride.
Fork with 160mm or 150mm travel and 150mm rear travel.*

The monocoque carbon frame allows you to have the following advantages:

Lightness

Carbon fiber is the material that offers the best weight/strength ratio.

Rigidity

Better distribution of forces, increasing the rigidity and reactivity of the bike.

Comfort

Vibration absorption.

Aerodynamics

The monocoque structure allows for more fluid and optimized shapes to reduce air resistance





CHEYENNE



FRAME	Full Carbon 29", Toray T700, Internal routing, Rear travel 150 mm, 12x148 mm E-Thru
FORK	Fox 36 Performance eMTB+, 160 mm, Air, 1.5 Tapered. FIT4, 15x110 mm
REAR SHOCK	Float X, Performance, EVOL, LSR, 2 Pos-Lever, 230x65
HEADSET	Acros AZF-575, 1,5", Internal routing
CRANKSET	Shimano Deore XT FC-M8100, 12s, Hollowtech 2, crank 170 mm, 30T
REAR DERAILLEUR	Shimano XT RD-M8100 SGS, Shadow Plus
SHIFTERS LEVERS	Shimano SLC SL-M-7100, Rapidfire-Plus, 12s
BRAKES	Shimano XT BR-M8120, Four piston, Rotor RT-MT800 203 mm / 203 mm
CASSETTE	Shimano CS-M6100 12s 10/51
PEDALS	Alu MTB Full +
WHEELS	Shimano XT WH-M620
STEM	Satori Ursa, 35 mm, Internal routing
HANDLEBAR	Race Face Chester, 780 mm, Rise 20
SEATPOST	Dropper Alpha 1, 31,6 mm, remote
SADDLE	Whistle Performance
TYRES	F: Schwalbe Magic Mary Evo, Addix Soft, Super Trail, 29"x2,60" R: Schwalbe Hans Dampf Evo, Addix Soft, Super Trail, 29"x2,60"

BLACK/GREEN/RED	
40	0116876000
44	0116876010
48	0116876020

MTB FULL SUSPENDED

COMANCHE



FRAME	Full Carbon 29", Toray T700, tapered, Rear travel 150 mm, 12x148 mm E-Thru
FORK	Fox 36 Float Rhythm, 150 mm, Air, Tapered, FIT GRIP Sweep-Adj, 15x110 mm
REAR SHOCK	Fox DPX2 Performance, 205x65, Trunion head, EVOL
HEADSET	FSA No.57E tapered 1"1/2
CRANKSET	Shimano XT FC-M8100, 30T, 170 mm
REAR DERAILLEUR	Shimano XT RD-M8100 SGS, Shadow Plus
SHIFTERS LEVERS	Shimano SLX SL-M7100 Rapidfire-Plus, 12s
BRAKES	Shimano XT - Front BR-M8120, Four piston, Rear BR-M8100, Two piston, Rotor RT-MT800 203 mm/180 mm
CASSETTE	Shimano CS-M6100 12s 10/51
PEDALS	Alu MTB Full +
WHEELS	Shimano WH-MT620
STEM	Alu Oversize, 55 mm, Bar bore 35 mm
HANDLEBAR	Rise Alu Oversize 35, 780 mm
SEATPOST	Dropper DP01, 31,6 mm, remote
SADDLE	Whistle Performance
TYRES	F: Schwalbe Magic Mary, Addix Soft compound, 29"x2,35" R: Schwalbe Hans Dampf Evo, Addix, 29"x2,35"

CARBON/ORANGE	
M	0116835210
L	0116835220



MTB HARDTAIL

Rigidità, affidabilità, resistenza e peso ridotto per una guida reattiva.

Stiffness, reliability, resistance and reduced weight for a more reactive drive.



MOJAG 2161



FRAME	Carbon Monocoque 29", tapered 1 1/2" Head Tube, Post mount disc brake, Press Fit 92, Bost 148x12mm rear axle, internal cables
FORK	Rock Shox Judy Silver 29" SoloAir, 100mm, tapered 1 1/2" steerer, Boost 110x15mm, with remote lockout
HEADSET	FSA No.42/ACB tapered 1 1/2"
CRANKSET	Shimano FC-MT510 Boost, 32T, Pressfit 92
REAR DERAILLEUR	Shimano XT RD-M8100 Shadow Plus, 12 speed
SHIFTERS LEVERS	Shimano Deore SL-M6100 12x1s
BRAKES	Shimano XT BR-M8100, Rotor SM-RT54 180mm F / 160mm R
CASSETTE	Shimano Deore CS-M6100 12s, 10/51T
WHEELS	Shimano WH-MT510 29" Boost 15mm/12mm, CL, 24h
STEM	Kyte Alu 3D forged
HANDLEBAR	Kyte TopFlat Alu DB, 720mm
SEATPOST	Kyte Alu 3D forged, 27,2mm
SADDLE	Whistle Performance
TYRES	Schwalbe Nobby Nic Performance 29x2,25

CARBON MATT/BLACK	
S	0116835000
M	0116835010

PATWIN 29" 2159 12S



FRAME	Alu formed tubes 29", internal cables, brake calliper on C/S
FORK	Suntour XCM RL 29" 100mm with remote lockout
HEADSET	FSA No.57BP-1 1 1/8
CRANKSET	Shimano FC-MT510, 32T, BSA
REAR DERAILLEUR	Shimano XT RD-M8100 Shadow Plus, 12 speed
SHIFTERS LEVERS	Shimano Deore SL-M6100 12x1s
BRAKES	Shimano BL-MT201/BR-MT200 hydraulic disc, Rotor SM-RT30 180mm F / 160mm R
CASSETTE	Shimano CS-M6100 12s, 10/51T
PEDALS	Alu MTB
HUBS	Shimano MT200/MT401, CL, 32h
RIMS	Whistle Alu double/wall, 32h, disc
STEM	Byte Kute Alu
HANDLEBAR	Byte Keek Flat Alu, 720mm
SEATPOST	Byte King Alu 30,9mm
SADDLE	Whistle with hole
TYRES	Schwalbe Rapid Rob 29x2,10

ULTRALIGHT/NEON RED	
S	0116833500
M	0116833510

PATWIN 29" 2379 LT 12S



FRAME	Alu formed tubes 29", internal cables, brake calliper on C/S
FORK	HL 860S HLO 29" 100mm with hydraulic lockout, 32mm stanchions
HEADSET	FSA No.57BP-1 1 1/8
CRANKSET	L-Twoo FC-A11, 32T, BSA
REAR DERAILLEUR	L-Twoo RD-A12-X, 12 speed
SHIFTERS LEVERS	L-Twoo SL-A12-X 12x1s
BRAKES	Shimano BL-MT201/BR-MT200 hydraulic disc, Rotor SM-RT10 180mm
CASSETTE	L-Twoo CS-A12 12s, 11/50T
PEDALS	Alu MTB
HUBS	Shimano TX505 CL, 32h
RIMS	Rodi Blackrock 23 double/wall, 32h, disc
STEM	Alu MTB Oversize
HANDLEBAR	Alu rise 25mm Oversize, 720mm
SEATPOST	Alu 30,9mm
SADDLE	Byte Sauris
TYRES	Byte Plöse 29x2,25

OCEAN MATT	
S	0116860400
M	0116860410
L	0116860420
BLACK/GOLD MATT	
S	0116860450
M	0116860460
L	0116860470



PATWIN 29" 2380 LT 12S



FRAME	Alu formed tubes 29", internal cables, brake calliper on C/S
FORK	HL 860S HLO 29" 100mm with hydraulic lockout, 32mm stanchions
HEADSET	FSA No.57BP-1 1 1/8
CRANKSET	L-Twoo FC-A11, 32T, BSA
REAR DERAILLEUR	L-Twoo RD-A12-X, 12 speed
SHIFTERS LEVERS	L-Twoo SL-A12-X 12x1s
BRAKES	Shimano BL-MT201/BR-MT200 hydraulic disc, Rotor SM-RT10 180mm
CASSETTE	L-Twoo CS-A12 12s, 11/50T
PEDALS	Alu MTB
HUBS	Shimano TX505 CL, 32h
RIMS	Rodi Blackrock 23 double/wall, 32h, disc
STEM	Alu MTB Oversize
HANDLEBAR	Alu rise 25mm Oversize, 720mm
SEATPOST	Alu 30,9mm
SADDLE	Byte Sauris
TYRES	Byte Plose 29x2,25

BLACK/GREEN MATT	
S	0116860650
M	0116860660
L	0116860670
LIGHT BLUE MATT	
S	0116860600
M	0116860610
L	0116860620



PATWIN 29" 2160 20S



FRAME	Alu formed tubes 29", internal cables, brake calliper on C/S
FORK	Suntour XCM RL 29" 100mm with remote lockout
HEADSET	FSA No.57BP-1 1"1/8
CRANKSET	Shimano Deore FC-M4100-2 2 Pieces, 36/26T, BSA
REAR DERAILLEUR	Shimano Deore RD-M5120 Shadow Plus, 10 speed
FRONT DERAILLEUR	Shimano Deore FD-M4100 Side Swing
SHIFTERS LEVERS	Shimano Deore SL-M4100 10s / SL-M5100 2s
BRAKES	Shimano BL-MT201/BR-MT200 hydraulic disc, Rotor SM-RT30 180mm F / 160mm R
CASSETTE	Shimano CS-M4100 10s, 11/42T
PEDALS	Alu MTB
HUBS	Shimano TX505 CL, 32h
RIMS	Whistle Alu double/wall, 32h, disc
STEM	Byte Kute Alu
HANDLEBAR	Byte Keek Flat Alu, 720mm
SEATPOST	Byte King Alu 30,9mm
SADDLE	Whistle Breath with hole
TYRES	Schwalbe Rapid Rob 29x2,10

BLACK/ORANGE	
S	0116833600
M	0116833610
L	0116833620

PATWIN 29" 2161 18S



FRAME	Alu formed tubes 29", internal cables, brake calliper on C/S
FORK	Suntour XCM RL 29" 100mm with remote lockout
HEADSET	FSA No.57BP-1 1 1/8
CRANKSET	Shimano Altus FC-MT210-2, 36/22T
REAR DERAILLEUR	Shimano Alivio RD-M3100 Shadow, 9 speed
FRONT DERAILLEUR	Shimano Alivio FD-M3120 Side Swing
SHIFTERS LEVERS	Shimano Alivio SL-M3100 9x2s
BRAKES	Shimano BL-MT200/BR-MT200 hydraulic disc, Rotor SM-RT10 180mm F / 160mm R
CASSETTE	Shimano CS-HG200 9s, 11/36T
PEDALS	Alu MTB
HUBS	Shimano TX505 CL, 32h
RIMS	Whistle Alu double/wall, 32h, disc
STEM	Byte Kute Alu
HANDLEBAR	Byte Keek Flat Alu, 720mm
SEATPOST	Byte King Alu 30,9mm
SADDLE	Whistle Breath with hole
TYRES	Schwalbe Rapid Rob 29x2,10

ANTHRACITE/BLACK	
S	0116833700
M	0116833710
L	0116833720

PATWIN 29" 2162 18S



FRAME	Alu formed tubes 29", internal cables, brake calliper on C/S
FORK	Suntour XCM RL 29" 100mm with remote lockout
HEADSET	FSA No.57BP-1 1"1/8
CRANKSET	Shimano FC-MT101 -2,36/22T
REAR DERAILEUR	Shimano Alivio RD-M3100, 9 speed
FRONT DERAILEUR	Shimano Alivio FD-M3120 Side Swing
SHIFTERS LEVERS	Shimano Alivio SL-M3100 9x2s
BRAKES	Shimano BL-MT200/BR-MT200 hydraulic disc, Rotor SM-RT10 160mm
CASSETTE	Shimano CS-HG200 9s, 11/36T
PEDALS	Steel MTB
HUBS	Shimano TX505 CL, 32h
RIMS	Whistle Alu double/wall, 32h, disc
STEM	Byte ahead Alu Oversize
HANDLEBAR	Byte Alu Oversize, flat, 720mm
SEATPOST	Byte Alu 30,9mm
SADDLE	Whistle Breath with hole
TYRES	Impac Ridgepac 29x2,10

ULTALIGHT/BLACK MATT	
M	0116833810
L	0116833820

PATWIN 29" 2163 16S



FRAME	Alu formed tubes 29", internal cables, brake calliper on C/S
FORK	Suntour XCM RL 29" 100mm with remote lockout
HEADSET	FSA No.57BP-1 1"1/8
CRANKSET	Shimano FC-M315-2, 36/22T
REAR DERAILLEUR	Shimano Acera RD-M360, 8 speed
FRONT DERAILLEUR	Shimano Altus FD-M315
SHIFTERS LEVERS	Shimano SL-M315 8x2s
BRAKES	Shimano BL-MT200/BR-MT200 hydraulic disc, Rotor SM-RT10 160mm
CASSETTE	Shimano CS-HG31 8s, 11/34T
PEDALS	Steel MTB
HUBS	Shimano TX505 CL, 32h
RIMS	Whistle Alu double/wall, 32h, disc
STEM	Byte ahead Alu Oversize
HANDLEBAR	Byte Alu Oversize, flat, 720mm
SEATPOST	Byte Alu 30,9mm
SADDLE	Whistle Breath with hole
TYRES	Impac Ridgepac 29x2,10

BLACK/NEON YELLOW	
S	0116833900
M	0116833910
L	0116833920

PATWIN 29" 2164 16S



FRAME	Alu formed tubes 29", internal cables, brake calliper on C/S
FORK	Suntour XCT30 HLO 29" 100mm with hydraulic lockout
HEADSET	FSA No.57BP-11"1/8
CRANKSET	Shimano FC-M315-2, 36/22T
REAR DERAILLEUR	Shimano Altus RD-M310, 8 speed
FRONT DERAILLEUR	Shimano Altus FD-M315
SHIFTERS LEVERS	Shimano ST-EF505 8x2s
BRAKES	Shimano BR-M200 hydraulic disc, Rotor SM-RT10 160mm
CASSETTE	Shimano CS-HG200 8s, 12/32T
PEDALS	Steel MTB
HUBS	Shimano TX505 CL, 32h
RIMS	Whistle Alu double/wall, 32h, disc
STEM	Byte ahead Alu Oversize
HANDLEBAR	Byte Alu Oversize, flat, 720mm
SEATPOST	Byte Alu 30,9mm
SADDLE	Whistle Breath with hole
TYRES	Impac Ridgepac 29x2,10

BLACK/NEON RED	
S	0116834000
M	0116834010
L	0116834020

PATWIN 29" 2165 21S



FRAME	Alu formed tubes 29", internal cables, brake calliper on C/S
FORK	Suntour XCT30 29" 100mm
HEADSET	FSA No.57BP-11"1/8
CRANKSET	Byte Alluminio 42/34/24
REAR DERAILLEUR	Shimano RD-TX500, 7 speed
FRONT DERAILLEUR	Shimano FD-TY500
SHIFTERS LEVERS	Shimano ST-EF505 7x3s
BRAKES	Shimano BR-M200 hydraulic disc, Rotor SM-RT10 160mm
CASSETTE	Shimano CS-HG200 7s, 12/32T
PEDALS	Steel MTB
HUBS	Shimano TX505 CL, 32h
RIMS	Whistle Alu double/wall, 32h, disc
STEM	Byte ahead Alu Oversize
HANDLEBAR	Byte Alu Oversize, flat, 720mm
SEATPOST	Byte Alu 30,9mm
SADDLE	Whistle Breath with hole
TYRES	Impac Ridgepac 29x2,10

NEON ORANGE/ANTHRACITE MATT	
S	0116834100
M	0116834110
L	0116834120

MIWOK 27,5" 2159 12S



FRAME	Alu formed tubes 27,5", internal cables, brake calliper on C/S
FORK	Suntour XCM RL 27,5" 100mm with remote lockout
HEADSET	FSA No.57BP-1 1 1/8
CRANKSET	Shimano FC-MT510, 32T, BSA
REAR DERAILLEUR	Shimano XT RD-M8100 Shadow Plus, 12 speed
SHIFTERS LEVERS	Shimano Deore SL-M6100 12x1s
BRAKES	Shimano BL-MT201/BR-MT200 hydraulic disc, Rotor SM-RT30 180mm F / 160mm R
CASSETTE	Shimano CS-M6100 12s, 10/51T
PEDALS	Alu MTB
HUBS	Shimano MT200/MT401, CL, 32h
RIMS	Whistle Alu double/wall, 32h, disc
STEM	Byte Kute Alu
HANDLEBAR	Byte Keek Flat Alu, 680mm
SEATPOST	Byte King Alu 30,9mm
SADDLE	Whistle with hole
TYRES	Schwalbe Rapid Rob 27,5x2,10

BLACK/NEON RED	
S	0116834200
M	0116834210
L	0116834220

MIWOK 27,5" 2160 20S



FRAME	Alu formed tubes 27,5", internal cables, brake calliper on C/S
FORK	Suntour XCM RL 27,5" 100mm with remote lockout
HEADSET	FSA No.57BP-1 1"1/8
CRANKSET	Shimano Deore FC-M4100-2 2 Pieces, 36/26, BSA
REAR DERAILLEUR	Shimano Deore RD-M5120 Shadow Plus, 10 speed
FRONT DERAILLEUR	Shimano Deore FD-M4100 Side Swing
SHIFTERS LEVERS	Shimano Deore SL-M4100 10s / SL-M5100 2s
BRAKES	Shimano BL-MT201/BR-MT200 hydraulic disc, Rotor SM-RT30 180mm F / 160mm R
CASSETTE	Shimano CS-M4100 10s, 11/42T
PEDALS	Alu MTB
HUBS	Shimano TX505 CL, 32h
RIMS	Whistle Alu double/wall, 32h, disc
STEM	Byte Kute Alu
HANDLEBAR	Byte Keek Flat Alu, 680mm
SEATPOST	Byte King Alu 30,9mm
SADDLE	Whistle with hole
TYRES	Schwalbe Rapid Rob 27,5x2,10

ANTHRACITE/BLACK	
S	0116834300
M	0116834310
L	0116834320

MIWOK PMX 3.2



FRAME	Alu formed tubes 27,5", internal cables, brake calliper on C/S
FORK	RST 100mm
HEADSET	FSA No.57BP-11"1/8
CRANKSET	Shimano BB-MT501, 2,36/22T
REAR DERAILLEUR	Shimano Alivio RD-M3100 Shadow, 9 speed
SHIFTERS LEVERS	Shimano Alivio SL-M3100 9x2s
BRAKES	Shimano BR-MT200 hydraulic disc, Rotor SM-RT10 160mm
CASSETTE	Shimano CS-HG200 9s, 11/36T
PEDALS	Steel MTB
HUBS	Shimano TX505 CL, 32h
RIMS	Whistle Alu double/wall, 32h, disc
STEM	Byte ahead Alu Oversize
HANDLEBAR	Byte Alu Oversize, flat, 680mm
SEATPOST	Byte Alu 30,9mm
SADDLE	Selle Italia
TYRES	Maxxis Pace 27,5x2,10

ULTALIGHT/ANTHRACITE/FUCSIA

Lady 43

0116846533

MIWOK 27,5" 2161 18S



FRAME	Alu formed tubes 27,5", internal cables, brake calliper on C/S
FORK	Suntour XCM RL 27,5" 100mm with remote lockout
HEADSET	FSA No.57BP-1 1"1/8
CRANKSET	Shimano Altus FC-MT210-2, 36/22T
REAR DERAILEUR	Shimano Alivio RD-M3100 Shadow, 9 speed
FRONT DERAILEUR	Shimano Alivio FD-M3120 Side Swing
SHIFTERS LEVERS	Shimano Alivio SL-M3100 9x2s
BRAKES	Shimano BL-MT200/BR-MT200 hydraulic disc, Rotor SM-RT10 180mm F / 160mm R
CASSETTE	Shimano CS-HG200 9s, 11/36T
PEDALS	Alu MTB
HUBS	Shimano TX505 CL, 32h
RIMS	Whistle Alu double/wall, 32h, disc
STEM	Byte Kute Alu
HANDLEBAR	Byte Keek Flat Alu, 680mm
SEATPOST	Byte King Alu 30,9mm
SADDLE	Whistle with hole
TYRES	Schwalbe Rapid Rob 27,5x2,10

ULTRALIGHT/NEON RED	
S	0116834400
M	0116834410
L	0116834420

MIWOK 27,5" 2162 18S



FRAME	Alu formed tubes 27,5", internal cables, brake calliper on C/S
FORK	Suntour XCM RL 27,5" 100mm with remote lockout
HEADSET	FSA No.57BP-1 1"1/8
CRANKSET	Shimano FC-MT101 -2,36/22T
REAR DERAILLEUR	Shimano Alivio RD-M3100, 9 speed
FRONT DERAILLEUR	Shimano Alivio FD-M3120 Side Swing
SHIFTERS LEVERS	Shimano Alivio SL-M3100 9x2s
BRAKES	Shimano BL-MT200/BR-MT200 hydraulic disc, Rotor SM-RT10 160mm
CASSETTE	Shimano CS-HG200 9s, 11/36T
PEDALS	Steel MTB
HUBS	Shimano TX505 CL, 32h
RIMS	Whistle Alu double/wall, 32h, disc
STEM	Byte ahead Alu Oversize
HANDLEBAR	Byte Alu Oversize, flat, 680mm
SEATPOST	Byte Alu 30,9mm
SADDLE	Whistle Breath with hole
TYRES	Impac Ridgepac 27,5x2,10

BLACK/NEON YELLOW	
S	0116834500
M	0116834510
L	0116834520

MIWOK 27,5" 2163 16S



FRAME	Alu formed tubes 27,5", internal cables, brake calliper on C/S
FORK	Suntour XCM RL 27,5" 100mm with remote lockout
HEADSET	FSA No.57BP-1 1"1/8
CRANKSET	Shimano FC-M315-2, 36/22T
REAR DERAILEUR	Shimano Acera RD-M360, 8 speed
FRONT DERAILEUR	Shimano Altus FD-M315
SHIFTERS LEVERS	Shimano SL-M315 8x2s
BRAKES	Shimano BL-MT200/BR-MT200 hydraulic disc, Rotor SM-RT10 160mm
CASSETTE	Shimano CS-HG31 8s, 11/34T
PEDALS	Steel MTB
HUBS	Shimano TX505 CL, 32h
RIMS	Whistle Alu double/wall, 32h, disc
STEM	Byte ahead Alu Oversize
HANDLEBAR	Byte Alu Oversize, flat, 680mm
SEATPOST	Byte Alu 30,9mm
SADDLE	Whistle Breath with hole
TYRES	Impac Ridgepac 27,5x2,10

ULTALIGHT/BLACK MATT	
M	0116834610
L	0116834620

MIWOK 27,5" 2164 16S



FRAME	Alu formed tubes 27,5", internal cables, brake calliper on C/S
FORK	Suntour XCT30 HLO 27,5" 100mm with hydraulic lockout
HEADSET	FSA No.57BP-1 1"1/8
CRANKSET	Shimano FC-M315-2, 36/22T
REAR DERAILLEUR	Shimano Altus RD-M310, 8 speed
FRONT DERAILLEUR	Shimano Altus FD-M315
SHIFTERS LEVERS	Shimano ST-EF505 8x2s
BRAKES	Shimano BR-M200 hydraulic disc, Rotor SM-RT10 160mm
CASSETTE	Shimano CS-HG200 8s, 12/32
PEDALS	Steel MTB
HUBS	Shimano TX505 CL, 32h
RIMS	Whistle Alu double/wall, 32h, disc
STEM	Byte ahead Alu Oversize
HANDLEBAR	Byte Alu Oversize, flat, 680mm
SEATPOST	Byte Alu 30,9mm
SADDLE	Whistle Breath with hole
TYRES	Impac Ridgepac 27,5x2,10

NEON ORANGE/ANTHRACITE MATT	
XS	0116834700
S	0116834710
M	0116834720
L	0116834730

MIWOK 27,5" 2165 21S



FRAME	Alu formed tubes 27,5", internal cables, brake calliper on C/S
FORK	Suntour XCT30 27,5" 100mm
HEADSET	FSA No.57BP-11"1/8
CRANKSET	Byte Alluminio 42/34/24
REAR DERAILLEUR	Shimano RD-TX500, 7 speed
FRONT DERAILLEUR	Shimano FD-TY500
SHIFTERS LEVERS	Shimano ST-EF505 7x3s
BRAKES	Shimano BR-M200 hydraulic disc, Rotor SM-RT10 160mm
CASSETTE	Shimano CS-HG200 7s, 12/32T
PEDALS	Steel MTB
HUBS	Shimano TX505 CL, 32h
RIMS	Whistle Alu double/wall, 32h, disc
STEM	Byte ahead Alu Oversize
HANDLEBAR	Byte Alu Oversize, flat, 680mm
SEATPOST	Byte Alu 30,9mm
SADDLE	Whistle Breath with hole
TYRES	Impac Ridgepac 27,5x2,10

BLACK/ORANGE	
XS	0116834800
M	0116834820
L	0116834830

GUIPAGO 2050-1614 FS



FRAME	Alu formed tubes Hybrid 700c, Post mount disc brake
FORK	Suntour NEX 700c 63mm
HEADSET	Integrated 1"1/8 ahead
CRANKSET	Byte Alluminio 48/38/28
REAR DERAILLEUR	Shimano Acera RD-M360
FRONT DERAILLEUR	Shimano Altus FD-M310
SHIFTERS LEVERS	Shimano ST-EF505 8x3s
BRAKES	Shimano BR-M200 hydraulic disc, Rotor SM-RT10 160mm
CASSETTE	Shimano CS-HG200 8s, 12-32T
PEDALS	Steel MTB
HUBS	Shimano TX505 CL, 36h
RIMS	Whistle Alu double/wall, 32h, disc
STEM	Byte ahead Alu Oversize, adjustable
HANDLEBAR	Byte Alu Oversize, rise 25mm, TTK
SEATPOST	Byte Alu 31,6mm
SADDLE	Selle Royal Lancia
TYRES	Schwalbe Delta Cruiser Plus 700x38, antiforatura, banda riflettente

ANTHRACITE/ULTRALIGHT	
M	0117100100



GEOMETRIES

- A** Lunghezza tubo sella
Seat tube lenght
- B** Lunghezza virtuale orizzontale
Top tube lenght - virtual
- C** Drop movimento centrale
Bottom braket drop
- D** Altezza movimento centrale
Bottom braket height
- E** Lunghezza carro
Chainstay lenght
- F** Angolo cannotto reggisella
Seat tube angle - actual
- G** Angolo tubo sella
Seat tube angle - effective
- H** Angolo sterzo
Head tube angle
- I** Offset forcella
Fork offset
- J** Distanza perni ruota
Wheelbase
- K** Lunghezza tubo sterzo
Head tube lenght
- L** Reach
Reacht
- M** Stack
Stack
- O** Avancorsa
Stack
- P** Lunghezza forcella
Fork length
- Q** Quota di standover
Standover height
- X** Lunghezza attacco manubrio
Stem lenght
- Y** Larghezza piega manubrio
Handlebar width
- Z** Escursione posteriore
Rear travel
- T** Lunghezza reggisella
Seat post lenght
- U** Statura consigliata
Advised height

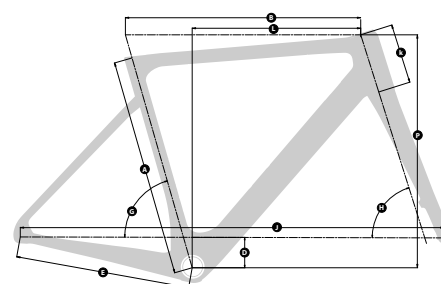
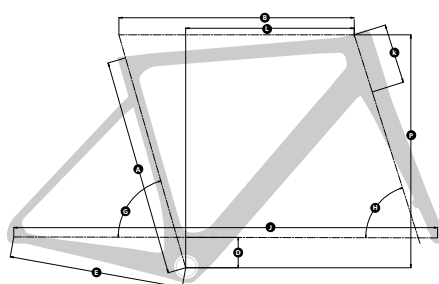
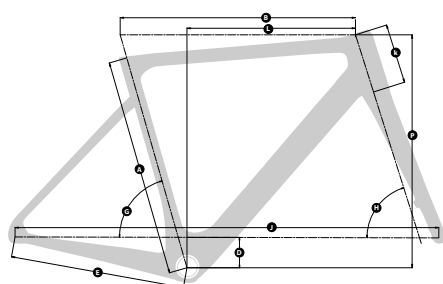

VAERO					
	49	52	54	56	58
A mm	470	490	510	530	550
B mm	510	530	550	565	585
C mm	71	71	71	71	71
D mm	302	302	302	302	302
E mm	408	408	408	408	408
G deg	75	75	75	75	75
H deg	71	71	71	71	71
I mm	43	43	43	43	43
J mm	972	979	990	997	1010
K mm	105	120	140	160	190
L mm	374	385	394	397	403
M mm	507	525	544	566	594
P mm	370	370	370	370	370
Q mm	774	807	841	877	914
Z mm	170	170	172.5	172.5	175
T mm	400	400	400	400	400
U mm	1,50-1,60	1,60-1,70	1,70-1,80	1,80-1,90	1,90-2,00
COCKPIT	100 x 400	100 x 400	110 x 420	110 x 420	120 x 420

KIOWA CARBON					
	48	51	54	57	60
A mm	480	510	540	570	600
B mm	540	560	580	600	615
C mm	80	80	80	80	80
D mm	300	300	300	300	300
E mm	430	430	430	430	430
G deg	74	73.5	73.5	73	73
H deg	70.5	71	71	71.5	71.5
I mm	55	55	55	55	55
J mm	1028	1039	1060	1070	1085
K mm	100	115	130	145	160
L mm	390	400	416	426	436
M mm	524	540	554	570	584
P mm	390	390	390	390	390
Q mm	824	876	931	989	1051
Z mm	170	170	172.5	172.5	175
T mm	400	400	400	400	400
U mm	1,50-1,60	1,60-1,70	1,70-1,80	1,80-1,90	1,90-2,00

KIOWA ALLOY					
	49	52	55	58	60
A mm	490	520	550	580	600
B mm	535	561	575	590	615
C mm	68	68	68	68	80
D mm	311	311	311	311	300
E mm	435	435	435	435	430
G deg	74	74	74	74	73
H deg	72	72	72	72	71.5
I mm	45	45	45	45	55
J mm	1016	1037	1052	1068	1085
K mm	120	140	155	175	160
L mm	385	400	410	420	436
M mm	542	561	575	594	584
P mm	390	390	390	390	390
Q mm	763	810	870	923	1051
Z mm	170	170	172.5	172.5	175
T mm	210	210	210	210	400
U mm	1,55-1,65	1,65-1,75	1,75-1,90	1,90-2,05	1,90-2,00

- A** Lunghezza tubo sella
Seat tube lenght
- B** Lunghezza virtuale orizzontale
Top tube lenght - virtual
- C** Drop movimento centrale
Bottom braket drop
- D** Altezza movimento centrale
Bottom braket height
- E** Lunghezza carro
Chainstay lenght
- F** Angolo canotto reggisella
Seat tube angle - actual
- G** Angolo tubo sella
Seat tube angle - effective
- H** Angolo sterzo
Head tube angle
- I** Offset forcella
Fork offset
- J** Distanza perni ruota
Wheelbase
- K** Lunghezza tubo sterzo
Head tube lenght
- L** Reach
Reacht
- M** Stack
Stack
- O** Avancorsa
Stack
- P** Lunghezza forcella
Fork lenght
- Q** Quota di standover
Standover height
- X** Lunghezza attacco manubrio
Stem lenght
- Y** Larghezza piega manubrio
Handlebar width
- Z** Escursione posteriore
Rear travel
- T** Lunghezza reggisella
Seat post lenght
- U** Statura consigliata
Advised height

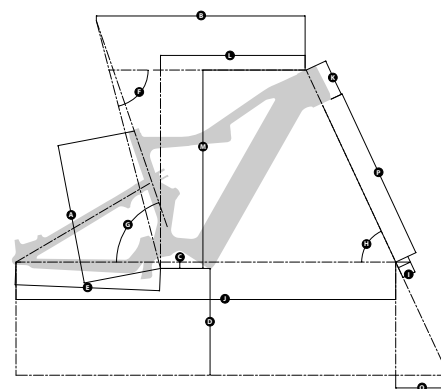
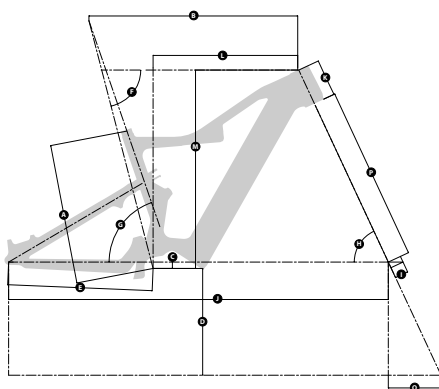
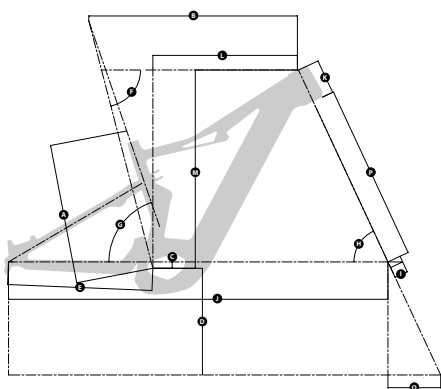

B-RUSH C / CA 2025

	S	M	L	XL
A mm	400	440	480	520
B mm	587	604	630	660
C mm	20	20	20	20
D mm	343	343	343	343
E mm	467	467	467	467
F deg	72	72	72	72
G deg	77	77	77	77
H deg	64	64	64	64
I mm	42	42	42	42
J mm	1211	1227	1253	1285
K mm	110	115	120	135
L mm	445	460	485	510
M mm	618	622	627	640
O mm	184	184	184	184
P mm	560	560	560	560
Q mm	691	694	711	719
Z mm	165	165	165	165
T mm	125	125	150	150
U m	1,55 - 1,65	1,65 - 1,75	1,75 - 1,90	1,90 - 2,05
Z mm	160	160	160	160

B-RUSH C 2024 / O-RUSH C 2025

	S	M	L	XL
A mm	400	440	480	520
B mm	593	611	639	669
C mm	20	20	20	20
D mm	342	342	342	342
E mm	455	455	455	455
F deg	71,0	71,0	71,0	71,0
G deg	76,4	76,4	76,4	76,4
H deg	65,0	65,0	65,0	65,0
I mm	29	29	29	29
J mm	1208	1227,5	1245	1276
K mm	105	115	120	135
L mm	445	460	485	510
M mm	613	622	631	645
O mm	175	175	175	175
P mm	560	560	560	560
Q mm	790	790	790	790
Z mm	165	165	165	165
T mm	125	125	150	150
U m	1,55 - 1,65	1,65 - 1,75	1,75 - 1,90	1,90 - 2,05
Z mm	160	160	160	160

O-RUSH C 2024

	S	M	L	XL
A mm	400	440	480	520
B mm	571	609	643	673
C mm	20	20	20	20
D mm	356	356	356	356
E mm	455	455	455	455
F deg	70	70	70	70
G deg	90	90	90	90
H deg	65,5	65,5	65,5	65,5
I mm	31	31	31	31
J mm	1177	1216,1	1250	1281
K mm	100	110	120	135
L mm	420	455	485	510
M mm	609	618	627	641
O mm	137	137	137	137
P mm	560	560	560	560
Q mm	726	733	747	766
Z mm	165	165	165	165
T mm	125	123	150	150
U m	1,55 - 1,65	1,65 - 1,75	1,75 - 1,90	1,90 - 2,05
Z mm	150	150	150	150

GEOMETRIES

- A** Lunghezza tubo sella
Seat tube lenght
- B** Lunghezza virtuale orizzontale
Top tube lenght - virtual
- C** Drop movimento centrale
Bottom braket drop
- D** Altezza movimento centrale
Bottom braket height
- E** Lunghezza carro
Chainstay lenght
- F** Angolo cannotto reggisella
Seat tube angle - actual
- G** Angolo tubo sella
Seat tube angle - effective
- H** Angolo sterzo
Head tube angle
- I** Offset forcella
Fork offset
- J** Distanza perni ruota
Wheelbase
- K** Lunghezza tubo sterzo
Head tube lenght
- L** Reach
Reacht
- M** Stack
Stack
- O** Avancorsa
Stack
- P** Lunghezza forcella
Fork length
- Q** Quota di standover
Standover height
- X** Lunghezza attacco manubrio
Stem lenght
- Y** Larghezza piega manubrio
Handlebar width
- Z** Escursione posteriore
Rear travel
- T** Lunghezza reggisella
Seat post length
- U** Statura consigliata
Advised height

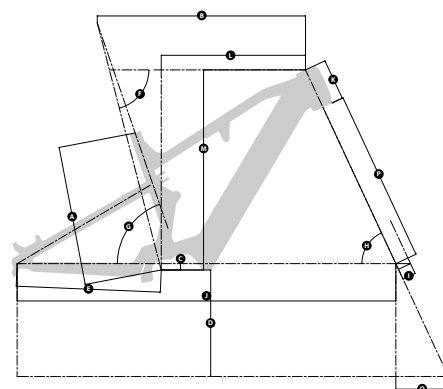
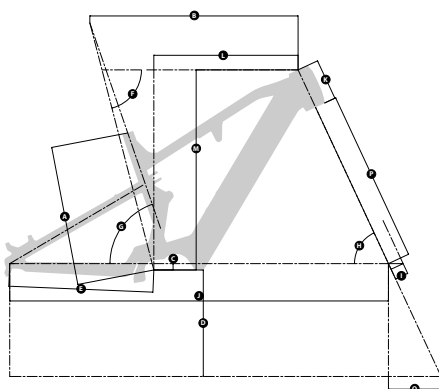
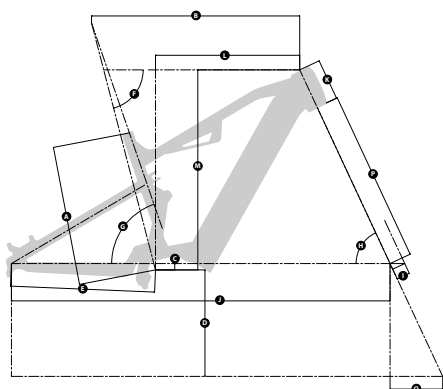

B-RUSH A 2025

	S	M	L	XL
A mm	400	440	480	520
B mm	605	620	646	672
C mm	20	20	20	20
D mm	343	343	343	343
E mm	467	467	467	467
F deg	71	71	71	71
G deg	75.6	75.6	75.6	75.6
H deg	64	64	64	64
I mm	42	42	42	42
J mm	1252	1267	1294	1321
K mm	130	130	135	140
L mm	445	460	485	510
M mm	622	622	626	631
O mm	184	184	184	184
P mm	560	560	560	560
Q mm	724	738	738	741
Z mm	165	165	165	165
T mm	125	125	150	150
U m	1,55 - 1,65	1,65 - 1,75	1,75 - 1,90	1,90 - 2,05
Z mm	160	160	160	160

B-RUSH A 2024 / O-RUSH A 2025

	S	M	L	XL
A mm	400	440	480	520
B mm	656	618	656	656
C mm	20	20	20	20
D mm	356	356	356	356
E mm	455	455	455	455
F deg	75	75	75	75
G deg	71	71	71	71
H deg	65	65	65	65
I mm	42	42	42	42
J mm	1241	1241	1275	1304
K mm	130	130	140	150
L mm	455	455	456	456
M mm	660	631	661	661
O mm	177	177	177	177
P mm	564	564	564	564
Q mm	728	767	802	833
Z mm	165	165	165	165
T mm	125	125	150	150
U m	1,55 - 1,65	1,65 - 1,75	1,75 - 1,90	1,90 - 2,05
Z mm	160	160	160	160

B-RUSH A 2022 / B-RUSH A 2024

	S	M	L	XL
A mm	400	440	480	520
B mm	610	632	656	656
C mm	20	20	20	20
D mm	356	356	356	356
E mm	470	470	470	470
F deg	70	70	70	70
G deg	80	80	80	80
H deg	65,5	65,5	65,5	65,5
I mm	44	44	44	44
J mm	1244	1266	1290	1290
K mm	135	135	135	135
L mm	445	467	491	491
M mm	637	637	637	637
O mm	123	123	123	123
P mm	563	563	563	563
Q mm	752	759	772	786
Z mm	165	165	165	165
T mm	125	125	150	150
U m	1,55 - 1,65	1,65 - 1,75	1,75 - 1,90	1,90 - 2,05
Z mm	150	150	150	150

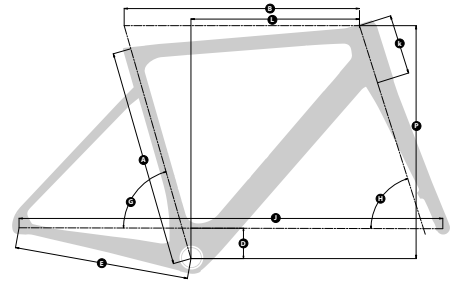
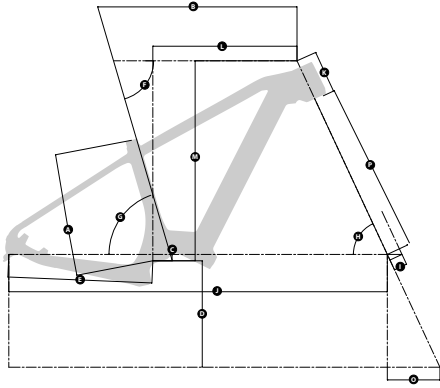

B-RACE C 2024 / O-RACE C 2024

	S	M	L
A mm	410	450	500
B mm	591,3	611,3	631
C mm	66	66	66
D mm	309,4	309,4	309,4
E mm	458	458	458
F deg	73,6	73,6	73,6
G deg	76,6	76,6	76,6
H deg	65,6	65,6	65,6
I mm	45	45	45
J mm	1200	1221	1243
K mm	105	115	125
L mm	442,1	459,4	476
M mm	628	638	647
O mm	169	169	169
P mm	530	530	530
Q mm	694	702	742
Z mm	170	175	175
T mm	125	150	150
U m	1,50-1,70	1,70-1,85	1,85-2,00

B-RACE A POWERTUBE

	S	M	L
A mm	400	460	500
B mm	590	605	620
C mm	50	50	50
D mm	305	305	305
E mm	480	480	480
F deg	74	74	74
G deg	76	76	76
H deg	68	68	68
I mm	46	46	46
J mm	1175	1190	1205
K mm	165	165	165
L mm	399	414	429
M mm	666	666	666
O mm	94	94	94
P mm	515	515	515
Q mm	714	765	797
Z mm	170	170	175
T mm	350	350	350
U m	1,50 - 1,70	1,70 - 1,85	1,85 - 2,00

E-FLOW

	M	L
A mm	535	575
B mm	538	550
C mm	72	72
E mm	460	460
F deg	74,3	73,5
G deg	74,3	73,5
H deg	72,5	73
I mm	45	45
J mm	1043	1068
K mm	130	150
L mm	475	497
M mm	536	556
O mm	576	585
P mm	370	370
Q mm	76	88
Z mm	170	175
T mm	350	350
U m	1,70 - 1,85	1,85 - 2,00

B-RACE E-BLADE

	M	L
A mm	460	520
B mm	630	663
C mm	50	50
D mm	323	323
E mm	460	460
F deg	72,5	72,5
G deg	72,5	72,5
H deg	66,5	66,5
I mm	51	51
J mm	1217	1251
K mm	150	150
L mm	445	475
M mm	647	656
O mm	165	165
P mm	530	530
Q mm	730	735,2
Z mm	170	175
T mm	350	350
U m	1,70-1,85	1,85-2,00

B-RACE POWERPACK

	M
A mm	460
B mm	600
C mm	62
D mm	308
E mm	510
F deg	73
G deg	73
H deg	68
I mm	46
J mm	1182,5
K mm	175
L mm	377,6
M mm	694,6
O mm	71,9
P mm	520
Q mm	747,9
Z mm	170
T mm	350
U m	1,70 - 1,85

B-RACE AM80

	S	M	L
A mm	420	460	500
B mm	600	615	630
C mm	50	50	50
D mm	320	320	320
E mm	500	500	500
F deg	73	73	73
G deg	73	73	73
H deg	69	69	69
I mm	46	46	46
J mm	1146	1161	1180
K mm	165	165	165
L mm	382	384	389
M mm	676	653	619
O mm	81	81	81
P mm	515	515	515
Q mm	690	720	735
Z mm	170	170	175
T mm	350	350	350
U m	1,50 - 1,70	1,70 - 1,85	1,85 - 2,00

SPEED URBAN

	S (LADY)	M (MAN)	L (MAN)
A mm	440	480	520
B mm	597	610	638
C mm	60	60	60
D mm	305	305	305
E mm	490	490	490
F deg	74	74	74
G deg	74	74	74
H deg	69	69	69
I mm	44	44	44
J mm	1183	1183	1211
K mm	170	165	180
L mm	413	426,5	450
M mm	645	640	654
O mm	145	145	145
P mm	470	470	470
Q mm	649	750	763
Z mm	170	170	175
T mm	350	350	350
U m	1,60 - 1,70	1,70 - 1,85	1,85 - 2,00

GEOMETRIES

- H** Lunghezza tubo sella
Seat tube lenght
- HCC** Lunghezza tubo sella - centro/centro
Seat tube lenght - centre/centre
- L** Lunghezza virtuale orizzontale
Top tube lenght - virtual
- L1** Lunghezza virtuale reale
Top tube lenght - real
- B** Drop movimento centrale
Bottom braket drop
- C** Lunghezza carro
Chainstay lenght
- A** Angolo canotto reggisella
Seat tube angle - actual
- A1** Angolo sterzo
Head tube angle
- S** Lunghezza tubo sterzo
Head tube length

FULL SUSPENDED											
MODEL & SIZE	H mm	HCC mm	L mm	L1 mm	A degrees	A1 degrees	A2 degrees	B mm	S mm	C mm	HEIGHT metres
COMANCHE											
M (16,5")	420		632		74,4°	65,5°		30	100	445	1.68 - 1.84
L (18")	460		656		74,4°	65,5°		30	115	445	1.85 - 1.98
CHEYENNE											
S	380		610		74,5°	66,5°		30	90	440	1.55 - 1.65
M	420		632		74,5°	66,5°		30	100	460	1.66 - 1.75
L	460		656		74,5°	66,5°		30	115	480	1.76 - 1.90
XL	460		680		74,5°	66,5°		30	135	500	1.76 - 1.90

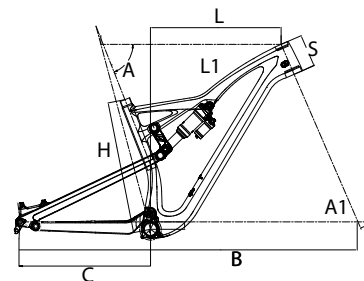
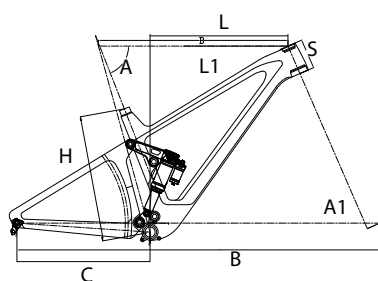

ROAD											
MODEL & SIZE	H mm	Hcc mm	L mm	L1 mm	A degrees	A1 degrees	A2 degrees	B mm	S mm	C mm	HEIGHT metres
MODOC HD											
18"	510	465	545	532	73.5°	72°	8°	68	115	420	1.65 - 1.76
20"	540	495	560	548	73°	73°	6.9°	68	135	420	1.76 - 1.90
MODOC											
18"	510	465	545	532	73.5°	73°	8°	68	125	405	1.65 - 1.76
20"	540	495	560	548	73°	73°	6.9°	68	145	405	1.76 - 1.90

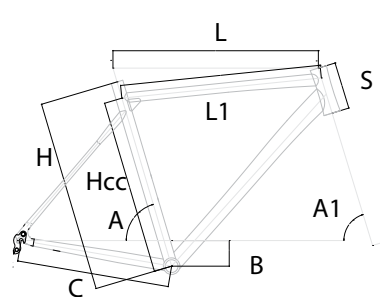
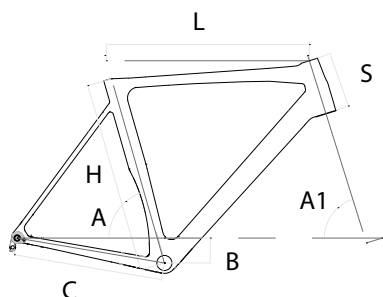

- H** Lunghezza tubo sella
Seat tube lenght
- HCC** Lunghezza tubo sella - centro/centro
Seat tube lenght - centre/centre
- L** Lunghezza virtuale orizzontale
Top tube lenght - virtual
- L1** Lunghezza virtuale reale
Top tube lenght - real
- B** Drop movimento centrale
Bottom braket drop
- C** Lunghezza carro
Chainstay lenght
- A** Angolo canotto reggisella
Seat tube angle - actual
- A1** Angolo sterzo
Head tube angle
- S** Lunghezza tubo sterzo
Head tube length

HARDTAIL											
MODEL & SIZE	H mm	Hcc mm	L mm	L1 mm	A degrees	A1 degrees	A2 degrees	B mm	S mm	C mm	HEIGHT metres
MOJAG											
S (17")	425	365	583	557	73°	70,5°		63	100	437	1.60 - 1.75
M (19")	475	415	605	572	73°	71°		63	105	437	1.75 - 1.90
PATWIN											
S (17")	430	330	580	560	73,5°	70°		58	100	475	1.60 - 1.70
M (19")	480	360	600	582	73,5°	70°		58	110	475	1.70 - 1.85
L (21")	530	410	620	596	73,5°	70°		58	120	475	1.85 - 2.00
MIWOK											
XS (14")	355	305	545	529	72,5°	70,5°	48	48	100	450	1.40 - 1.55
S (16")	410	310	560	548	72,5°	70,5°	48	48	110	450	1.55 - 1.70
M (18")	460	340	582	563	72,5°	70,5°		48	120	450	1.70 - 1.80
L (20")	510	390	604	578	72,5°	71°		48	130	450	1.80 - 1.95

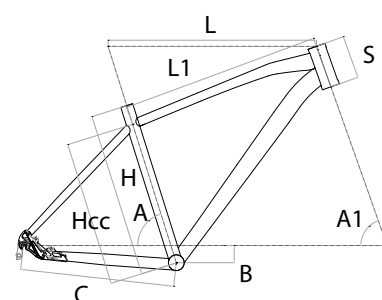
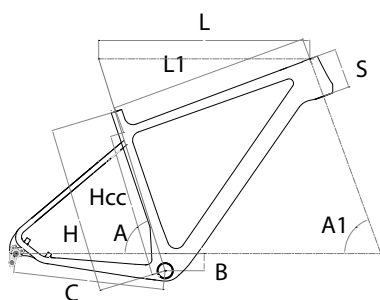

TREKKING											
MODEL & SIZE	H mm	Hcc mm	L mm	L1 mm	A degrees	A1 degrees	A2 degrees	B mm	S mm	C mm	HEIGHT metres
GUIPAGO											
M (49)	490	435	570	548	73°	71°	8.8°	45	145	445	1.60 - 1.75

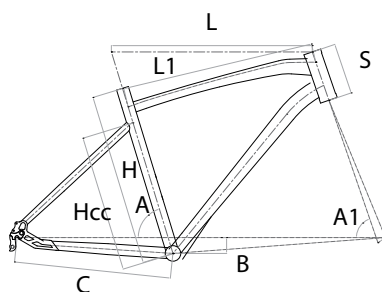

SERVICE

Gentile Rivenditore,
per essere in grado di consentire una rapida e veloce elaborazione delle domande e dei reclami e di offrire il miglior servizio possibile, è essenziale prendere conoscenza di tutte le informazioni necessarie riportate qui in forma sintetica.

Nelle pagine seguenti trova tutte le informazioni importanti riguardo la garanzia, le norme ed il trattamento dei reclami (ad esempio i danni da trasporto).

Ulteriori informazioni più specifiche sui nostri prodotti si trovano nel nostro manuale di base Atala / Whistle allegato a ciascuna delle nostre biciclette.

Dear specialist dealer,
to being able to grant a smooth and quick processing of your enquires and complaints and to offer you the best service possible it is essential that we receive all necessary information promptly and in compressed form.

On the following pages we would like to provide all important information amongst others about warranty, rules and complaint processing (e.g. damage in transport).

Furthermore specific information about our products and these topics you can find in our Atala/Whistle basic manual, which is enclosed to each of our bicycles.

I PRATICA DI ASSISTENZA

Per garantire una rapida elaborazione, la pratica di assistenza in forma scritta e con tutti i documenti necessari, deve essere inserita nel nostro sistema assistenza.atala.it.

Di seguito informazioni importanti riguardanti i reclami relativi ai danni al trasporto e alla consegna non completa:

Le merci consegnate devono essere controllate per verificare la presenza di tutti i componenti e i danni esterni al momento del ricevimento.

Eventuali danni devono essere confermati dall'autista sul documento di trasporto in maniera estesa. Non è valida una "riserva di controllo", ma va riportata la causa esatta della riserva stessa (ad esempio "Riserva per collo aperto", "Riserva per collo schiacciato").

Eventuali danni e mancanza di componenti quali manuali, documentazioni del veicolo e/o componenti o accessori, devono essere comunicati in forma scritta entro otto giorni lavorativi dal ricevimento della merce.

INFORMAZIONI IMPORTANTI SUI RECLAMI DA PARTE DEI CONSUMATORI FINALI PRESSO RIVENDITORE SPECIALIZZATO

Con riferimento al prodotto oggetto della segnalazione, il consumatore deve rivolgersi al rivenditore con i seguenti documenti:

prova di vendita e data di consegna, quale prova di acquisto come fattura, scontrino o bolla di consegna del veicolo.

Una segnalazione valida da parte del consumatore, può essere effettuata solo tramite il rivenditore presso il quale è stato acquistato il prodotto e con il quale è stato concluso il contratto di vendita.

Se il proprietario della bicicletta si reca da un altro rivenditore rispetto a dove è stato acquistato per eseguire una segnalazione, Atala non dovrà sostenere eventuali costi derivanti, che devono essere pagati dal consumatore.

Atala si riserva il diritto di addebitare i costi di trattamento per reclami non giustificati.

INFORMAZIONI IMPORTANTI SUL RITIRO DI BICICLETTE

Richiedere il ritiro di un pezzo, di un accessorio o di una bicicletta difettosa tramite il portale dedicato all'assistenza.

Atala accetta solamente la consegna di biciclette che sono state ritirate secondo la procedura.

Verranno respinte tutte le scatole restituite senza l'ordine di ritiro. Per il ritiro ingiustificato di biciclette, Atala si riserva il diritto di addebitare il trasporto, nonché una tassa di gestione.

I pedali devono essere smontati, il manubrio deve essere girato lateralmente e gli oggetti personali devono essere già stati rimossi dalla bicicletta da parte del rivenditore. Se ciò non dovesse avvenire, queste parti possono essere re-imballate in una scatola per la riconsegna.

Atala non sarà responsabile in caso di perdita di alcuno di questi accessori.

Le batterie devono essere inserite nella rispettiva sede e devono essere spediti anche il caricatore, il display e le chiavi.

Deve essere inclusa una copia della fattura del consumatore e un modulo di non conformità completamente compilati.

Le biciclette ritirate devono essere pulite e trasportabili che significa imballate in custodia protettiva, inclusi manubrio e sella per evitare danni al trasporto. Lo spedizioniere non accetterà le biciclette non imballate. Se non è in grado di imballare la stessa come indicato, contatti il nostro team di assistenza.

Al momento del ritiro del veicolo, riceverà una copia firmata del documento di trasporto dal vettore.

Non accettiamo le seguenti ragioni per il ritiro:

- ordine non corretto
- regolazione del cambio o del freno
- centraggio della ruota

I COMPLAINT PROCESSING

To grant a quick processing the complaint, in written form with all necessary documents, has to be registered in our system.

Important information regarding complaints concerning transport damages and non-complete delivery:

The delivered goods have to be checked for completeness and external damage upon receipt. Possible damages have to be confirmed by the driver on the consignment note in an extended way. Writing "Subject to check" is not valid, but you should write the real cause (for example, "Subject to check because box is open" or "Subject to check because box is crushed").

Hidden damage and non-completeness by missing manuals, vehicle documents and/or missing mounting parts or accessories have to be communicated in written form after eight working days at the latest.

IMPORTANT INFORMATION ON COMPLETE COMPLAINTS BY END CONSUMERS AT THE SPECIALIST DEALER

Besides the product concerned by the complaint, the consumer has to approach the dealer with the following documents:

Proof of sale, date of delivery which is a proof of purchase like invoice or receipt of the vehicle or part.

A valid complaint by the consumer can only be made at the dealer at which he bought the product that is the dealer with whom the sales contract was concluded.

If the vehicle owner instructs another dealer than the dealer where the vehicle was bought with the complaint, Atala will not bear any possibly arising costs – these have to be paid by the customer himself.

Atala reserves the right to charge an additional processing fee for not justified complaints.

IMPORTANT INFORMATION ON BICYCLE COLLECTION

Arrange pick-up of a defective bicycle mounting part or accessory via our technical support system.

We can only accept delivery of bicycles which have been picked-up on our account.

We have to decline acceptance of any bicycles which are returned to us without pick-up order.

For not justified bicycle collection we reserve the right to charge you the freight costs for transport and possible re-shipment as well as a handling fee.

Pedals must be demounted, the handlebar must be turned sideways and personal items should have already been removed from the bicycle by the dealer. If this should not happen, these parts may only be packed in the box loosely for reshipment. We will not be liable for any loss.

Batteries have to be put in the respective socket including charger, display and key(s). A copy of the consumer invoice and a completely filled compliant form has to be included. Bikes retrieved by us have to be cleaned and in transportable state which means packed in slipcase, handlebar and saddle protection to prevent transport damage.

The forwarder will not accept unpacked bicycles. If you are not able to pack the bicycle as mentioned, please contact our service team.

Upon pick-up of the vehicle you will receive a signed copy of the consignment note from the carrier.

We do not accept the following reasons for a bike retrieval:

- incorrect order
- adjustment work at gear or brake
- wheel re-centering

GARANZIA

I prodotti Atala sono garantiti dal venditore secondo quanto previsto dalle attuali norme di legge vigenti in materia. Non sono coperte da garanzia Atala tutte le parti meccaniche ed i componenti per i quali vale la garanzia del fabbricante.

L'azienda si riserva il diritto di modificare le immagini ed i componenti in ogni momento e senza alcun preavviso.

WARRANTY

Atala's products are guaranteed by the dealer in accordance with the current Italian laws in force. All the other mechanical parts or components are not included in this warranty but are under the manufacturer's warranty.

The company reserves the right to modify pictures and the bicycle parts at any time without prior notice.

Prezzo di listino consigliato al pubblico, iva inclusa. Prezzi soggetti a modifiche da parte di Atala S.p.A.

The price included VAT and may be modified by Atala S.p.A.

Il peso della bici potrebbe variare in base alla taglia di circa il 5%.

The weight of the bike may vary according to the size by approximately 5%.

I DIFETTI DI MATERIALE

DIRITTI DEI COMPRATORI

Secondo le leggi di garanzia europee, aggiornate il 1° gennaio 2002, il rivenditore è responsabile per i difetti dei materiali per un periodo di due anni. Questo periodo inizia con la consegna del prodotto dal rivenditore al cliente. All'interno del periodo obbligatorio della durata di 2 anni, è da considerare anche il periodo di inversione dell'onere della prova fissato in 6 mesi oltre la data di consegna del prodotto. Ciò significa che il legislatore ha stabilito che qualsiasi difetto che si verifichi entro 6 mesi dalla consegna del prodotto era pre-esistente al momento della consegna stessa. Pertanto, in tal caso, qualora si verifichi un difetto, il venditore deve dimostrare che questo era inesistente al momento della consegna o è stato causato da uso improprio o usura correlata all'utilizzo. Passato questo periodo è il compratore a dover fornire questa prova.

LA RESPONSABILITÀ PER I MATERIALI NON COPRE:

Difetti causati da uso improprio o forza maggiore.

Qualsiasi parte del veicolo soggetto a usura e usura a causa dell'utilizzo, purché non vi siano difetti di produzione o difetti nel materiale. Difetti causati da uso improprio, manutenzione insufficiente e riparazioni, conversioni o sostituzioni delle parti del veicolo eseguita da personale non qualificato. Ciò include, ad esempio, la manipolazione del motore di una eBike. Difetti causati dalla mancata osservanza di una sostituzione potenzialmente necessaria dei componenti relativi alla sicurezza, come manubri, freni etc.

Difetti dovuti ad incidenti o ad altre influenze esterne, a condizione che non siano causate da componenti difettose o guasti del prodotto.

Riparazioni effettuate con componenti usati o guasti derivanti da tali riparazioni

Difetti dovuti all'uso durante una competizione, a meno che non vi sia una esplicita autorizzazione. Componenti montati successivamente che non rientrano nell'ambito della consegna al momento della vendita o errori derivanti dall'assemblaggio non professionale di tali parti.

Danni causati dal mancato rispetto del peso massimo consentito del veicolo o dall'utilizzo non conforme alle restrizioni all'uso (sedili per bambini, ecc.)

Veicoli di seconda mano in cui è già avvenuto un cambiamento di proprietà.

I MATERIAL DEFECTS

BUYER'S RIGHTS

According to the European Warranty laws, adjusted on January 1st 2002, the retailer is liable for material defects for a period of 2 years. This period starts with the delivery of the product from the retailer to the customer.

Besides the fundamental 2 year period, there is also the legal so-called reversal of the burden of proof 6 months past the date of the product's delivery. This means that the legislator set a fiction that any defect that occurs within 6 months of delivery of the product was pre-existent at the time of delivery. Therefore in this case if a defect occurs the seller has to prove that the defect was non-existent at the time of delivery or was caused by improper use or function-related wear. Past that period the buyer has to proof the reverse.

THE LIABILITY FOR MATERIAL DEFECTS DOES NOT COVER:

Defects that were caused by improper use or force majeure

Any parts of the vehicle that are subject to function-related wear and tear, as long as there are no manufacturing defects or faults in material

Defects that were caused by improper or insufficient case and unprofessionally performed repairs, conversions or replacement of vehicle parts. This includes, the manipulation of the drive system of an eBike.

Defects that were caused by disregard of a potentially necessary replacement of safety related components, like handlebars, brakes and so on.

Defects due to accidents or other usual external influences as long as they are not caused by faulty information or product failures. Repairs, that use second-hand components or faults resulting from such repairs.

Defects due to competitive use of a product that has no explicit competition clearance.

Retrofitted parts, that are not part of the scope of delivery at the time of the product transfer of faults resulting from the unprofessional assembly of such parts.

Damages caused by not observing the maximum permissible weight of the vehicle or not complying with the restrictions on use (child seat, etc).

Second-hand vehicles where a change of ownership has already taken place.





CONSEGNA DELLE PARTI DI RICAMBIO IN ANTICIPO

Si prega di notare i seguenti punti quando si richiede la consegna anticipata di un pezzo di ricambio prima di presentare un modulo di non conformità adeguato:

- I ritiri necessari saranno organizzati da Atala.
- Tutti i componenti di valore significativo che saranno anticipati, lo saranno in "conto anticipo": se su richiesta di Atala il componente difettoso non sarà restituito nel mese, il conto anticipo genererà una fattura di vendita del componente stesso.
- Le segnalazioni ingiustificate verranno restituite al rivenditore a proprie spese – Atala si riserva una commissione di gestione.
- Per le segnalazioni di difettosità di parti di veicoli o accessori dei marchi nella tabella sottostante, questi devono essere restituiti direttamente al produttore o al distributore con relativa ricevuta.

SPARE PART DELIVERY IN ADVANCE

Please note, before submitting a compliant, the following points when applying for a spare part delivery:

- Necessary pick-ups will be arranged by us.
- All parts with a significant value that are sent in advance, will be sent in "advance replacement" form: if under Atala request, the defective component will not be sent back within one month, an invoice for the component will be automatically generated.
- Not justified complaints will be returned to the dealer at his own cost we reserve a processing fee.
- For complaints of vehicle parts or accessories by the below mentioned brands, these have to be returned directly to the manufacturer or distributor with receipt.

MARCHIO BRAND	PRODUTTORE O DISTRIBUTORE/ MANUFACTURER OR DISTRIBUTOR	INDIRIZZO ADDRESS	TELEFONO PHONE	E-MAIL WEB
<i>Bosch</i>	<i>Magura GmbH</i>		<i>+39 0299953659</i>	<i>service@bosch-ebike.it</i>
<i>Sram / Rock Shox</i>	<i>Beltrami TSA srl</i>	<i>via Euripide 7 Reggio Emilia</i>	<i>+39 0522300523</i>	<i>info@beltramitsa.it</i>
<i>Fox</i>	<i>Vittoria S.p.A.</i>	<i>Via Papa Giovanni XXIII 1 Madone (BG)</i>	<i>+39 0354993911</i>	<i>service.vittoria.com</i>
<i>FSA</i>	<i>F.S.A. s.r.l.</i>	<i>Via del Lavoro 56 Busnago (MB)</i>	<i>+39 0396885265</i>	
<i>Shimano</i>	<i>Shimano Italy Bicycle Components</i>	<i>Strada Statale del Sempione, 197 Pero (MI)</i>	<i>+39 0238592097</i>	<i>assistenza@shimano-eu.com</i>
<i>Schwalbe</i>	<i>Schwalbe Italia s.r.l.</i>	<i>Via Giuseppe Verdi 3 Agrate Brianza (MB)</i>	<i>+39 0396058078</i>	<i>info@schwalbe.it</i>
<i>Ananda</i>	<i>Marcon Italy Service Station</i>	<i>Via D.G Zanchette 6 Cassola (VI)</i>	<i>+39 3457959644</i>	<i>ext.marcon@ananda-service.com</i>
<i>SR Suntour</i>	<i>Antonio Rullo</i>	<i>Via Manzoni 368 2Cassina Rizzardi (CO)</i>	<i>+39 031934573</i>	<i>info@assistenzarullo.com</i>
<i>RST</i>	<i>GB center</i>		<i>+39 0423040109</i>	<i>assistenza@gb-center.it</i>
<i>OLI</i>	<i>OLI</i>	<i>Via delle Pesche, 821 Cesena (FC) Italy</i>	<i>+39 3240112421</i>	<i>customerservice@oli-ebike.com</i>
<i>Mavic</i>	<i>GB center</i>		<i>+39 3346582496</i>	<i>techservice.it@mavic.com</i>

La richiesta di gestire attraverso Atala la pratica comporterà l'addebito dei costi al rivenditore e un significativo prolungamento dei tempi di soluzione della stessa a causa di un doppio passaggio. In questo caso inoltre, la decisione per la soluzione pratica rimane di completa pertinenza del produttore a cui è indirizzata.

WHISTLE

2025

ATALA S.P.A.

Via della Guerrina, 108
20900 Monza (MB)
Tel. +39 039 2045311

www.whistlebikes.com

